

PANEL CUT-OUT  
 PANEL THICKNESS: .031-.063 (0.8-1.6)

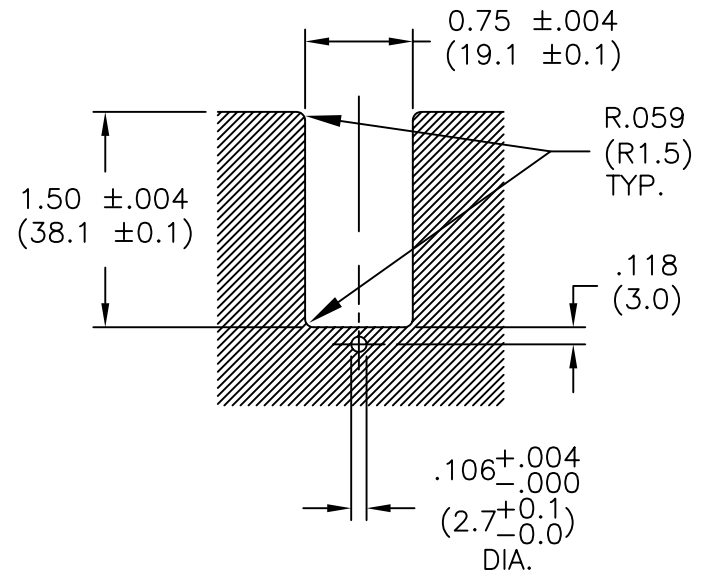

NOTES:

1. MATERIAL: NYLON 66 (RMS-01).  
 FLAME RETARDANT NYLON (RMS-19)  
 AVAILABLE BY SPECIAL ORDER.
2. COLOR: NATURAL.

A	CHANGED NOTE 1, CHANGED TITLE BLOCK	SJ 03.27.02
REV	DESCRIPTION	ENGR DATE

TITLE: EDGING SADDLE						DWG IN IN(mm)	
TOLERANCES UNLESS NOTED .XX=.010 .XXX=.005 FRAC=1/64 ANG=1°		FILE # LEWSE-18.4	DWN: J.B.	APP:	FINAL		
MAT'L: SEE NOTES		DT: 06-26-97	DT:	PART #		PRINT TYPE	
RE: RICHCO INC		RICHCO INC. PO BOX 804238, CHICAGO, 60680 (773) 539-4060		LEWSE-18.4-01		CA	