

FTH-37-1-ASS AVAILABLE BY SPECIAL ORDER - NAFTA REGION ONLY.

MATERIAL UL94 V-2 NYLON 6/6 (RMS-01) COLOUR:BLACK

PART NUMBER	PANEL HOLE ϕ	PANEL THICKNESS	CABLE TIE ACCEPTED	ASSEMBLED CABLE TIE		
				MIN LOOP TENSILE STRENGTH (kg)	LENGTH	MAX BUNDLE ϕ
FTH-37-01BK	6.5 - 7 [.26 - .28]	.8 - 3 [.03 - .12]	RG-211/311, -212/312, -213/313, -215/315, -216/316C, 217/317, 218/318, 219/319, 220/320	-	-	-
FTH-37-1-ASS			RG-311 (ASSEMBLED)	22.4	160	40

OTHER COLOURS AND MATERIALS AVAILABLE BY SPECIAL ORDER

REV.	MODIFICATION.	DATE	DRN
01	PRODUCTION RELEASE	29/09/08	MT
02	CO2010497	03/12/08	SF
03	CO2011059	16/02/11	SF

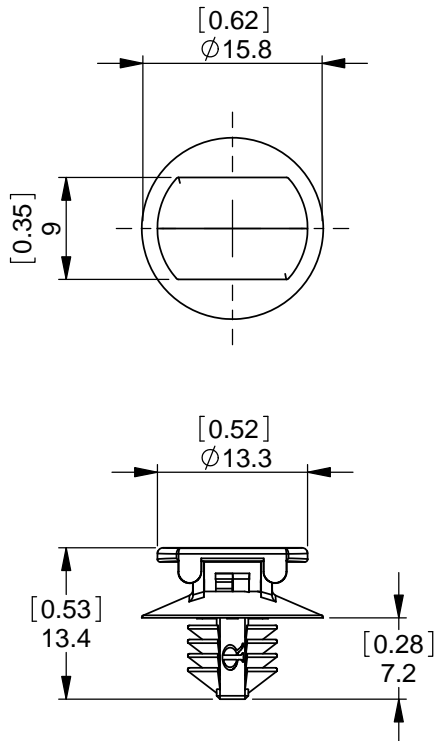

ALTERNATE UNITS FOR REFERENCE ONLY

INFORMATION CONTAINED IN THIS DOCUMENT IS CONFIDENTIAL TO RICHCO INTERNATIONAL Co. Ltd. AND MAY NOT BE DISCLOSED OR REPRODUCED IN WHOLE OR PART WITHOUT THEIR WRITTEN CONSENT.

RICHCO, INC.
WWW.RICHCO-INC.COM

METRIC PRIMARY UNITS:mm
IMPERIAL SECONDARY UNITS:[inches]
GENERAL TOLERANCES ± 0.25 [0.010]
UNLESS OTHERWISE STATED
1 DECIMAL PLACE \pm
2 DECIMAL PLACES \pm
ANGULAR $\pm 1^\circ$

THIRD ANGLE

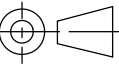

MATERIAL: NYLON 6/6 UL94 V-2 (RMS-01)		COLOUR: BLACK	
DESCRIPTION: FIR TREE CABLE TIE HOLDER		PART No: SEE TABLE	
DRG No: 07-124	NPR No: 2006-212	Mass:(g) 0.35	SHEET SIZE A4
DRN MT	DATE 23/04/08	CHKD BO	DATE 21/05/08
SCALE NTS		SHEET No. 1 OF 1	