

FTH-33-1-ASS AVAILABLE BY SPECIAL ORDER - NAFTA REGION ONLY.

REV.	MODIFICATION.	DATE	DRN
01	NEW SALES DWG	22/10/07	NJB
02	ECN07-217	30/11/07	SF
03	CO-2010225	09/05/08	OW
04	CO2010349	27/08/08	SF
05	CO2010404	23/09/08	SF
06	CO2010497	03/12/08	SF
07	CO2011094	24/02/11	SF

MATERIAL UL94 V-2 NYLON 6/6 (RMS-01)							
PART NUMBER	COLOUR	PANEL HOLE ϕ	PANEL THICKNESS	CABLE TIE ACCEPTED	CABLE TIE		
					MIN LOOP TENSILE STRENGTH (kg)	LENGTH	MAX BUNDLE ϕ
FTH-33-01	NATURAL	6.4[.251]	1.4 - 2[.055-.078]	ALL RG CABLE TIES UP TO SIZE RG-211/311	-	-	-
FTH-33-1-ASS	BLACK			RG-311(ASSEMBLED)	22.4	160	40
OTHER COLOURS AND MATERIALS AVAILABLE BY SPECIAL ORDER							

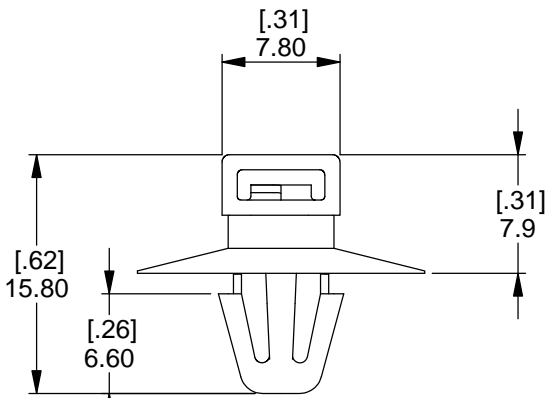
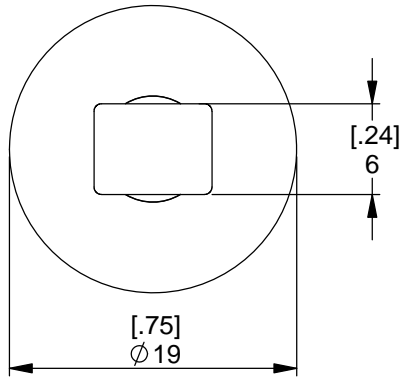

INFORMATION CONTAINED IN THIS DOCUMENT IS CONFIDENTIAL TO RICHCO INTERNATIONAL Co. Ltd. AND MAY NOT BE DISCLOSED OR REPRODUCED IN WHOLE OR PART WITHOUT THEIR WRITTEN CONSENT.

RICHCO, INC.
 WWW.RICHCO-INC.COM

GENERAL TOLERANCES ± 0.25 [0.010]
 UNLESS OTHERWISE STATED
 1 DECIMAL PLACE \pm
 2 DECIMAL PLACES \pm
 ANGULAR $\pm 1^\circ$

THIRD ANGLE

MATERIAL: SEE TABLE COLOUR: SEE TABLE

DESCRIPTION: FLAT TIE HOLDER, CUPPED BASE PART No: SEE TABLE

DRG No: 07-112 NPR No: 2006-160 Mass:(g) 0.5 SHEET SIZE A4

DRN NJB DATE 22/10/07 CHKD SF DATE 22/10/07 SCALE NTS SHEET No. 1 OF 1

FORM No. 0145/03