

REV.	MODIFICATION.	DATE	DRN
01	CO2011084	21/02/11	SF

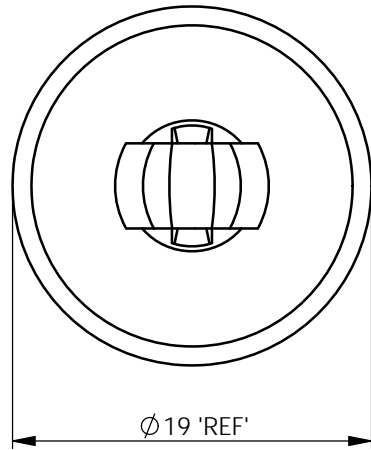
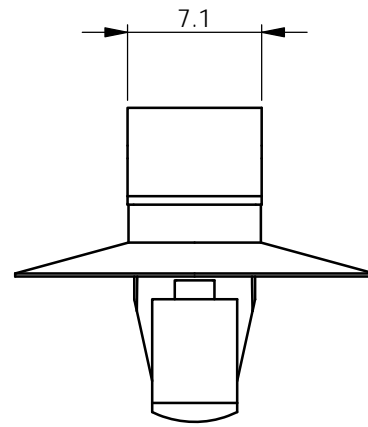
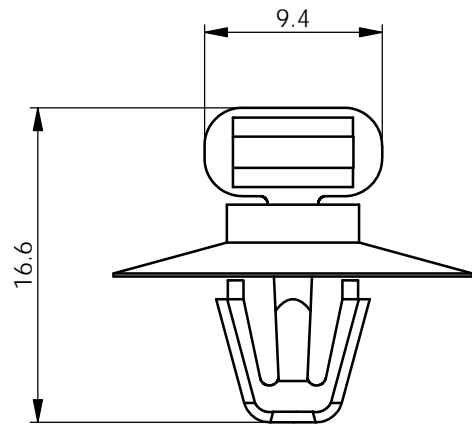

MATERIAL: UL94 V-2 NYLON 6/6, RMS-01* COLOUR: NATURAL			
PART No.	HOLE Ø	PANEL THICKNESS	CABLE TIE ACCEPTED
FTH-29-01	6.35 ± 0.08	1.6	ALL RG CABLE TIES UP TO SIZE RG-220/320
*AVAILABLE IN UL94 V-0 BY SPECIAL ORDER. TO ORDER REPLACE -01 WITH -19.			

INFORMATION CONTAINED IN THIS DOCUMENT IS CONFIDENTIAL TO RICHCO INTERNATIONAL Co. Ltd. AND MAY NOT BE DISCLOSED OR REPRODUCED IN WHOLE OR PART WITHOUT THEIR WRITTEN CONSENT.

RICHCO, INC.
WWW.RICHCO-INC.COM

GENERAL TOLERANCES ±0.25 [0.010]
UNLESS OTHERWISE STATED
1 DECIMAL PLACE ±
2 DECIMAL PLACES ±
ANGULAR ±1°

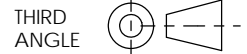

MATERIAL: SEE TABLE		COLOUR: SEE TABLE	
DESCRIPTION: FLAT TIE HOLDER		PART No: SEE TABLE	
DRG No: 011-031	NPR No:	SHEET SIZE A4	
DRN SF	DATE 21/02/11	CHKD JK	DATE 21/02/11
SCALE NTS	SHEET No. 1 OF 1		