

A B C D E F

REV.	MODIFICATION.	DATE	DRN
01	CO2011073	18/02/11	SF

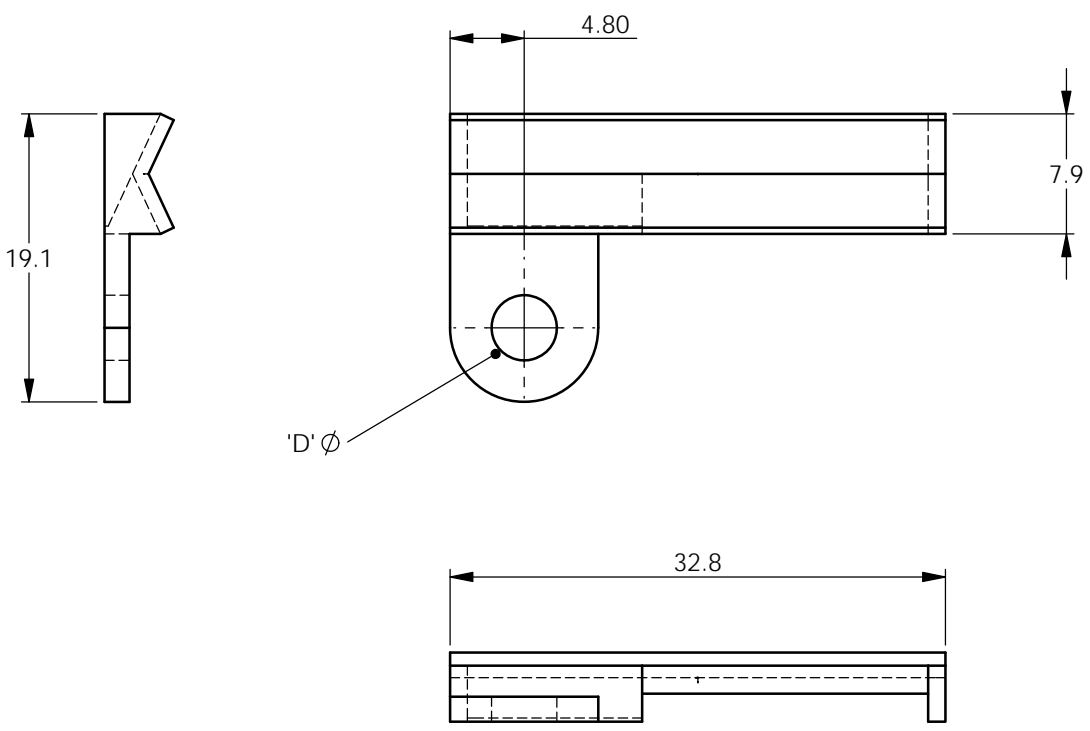

MATERIAL: UL94 V-2 NYLON 6/6, RMS-01* COLOUR: NATURAL		
PART No.	'D' Ø	CABLE TIE ACCEPTED
FTH-11-8-01	4.3	ALL RG CABLE TIES UP TO SIZE RG-220/320
FTH-11-10-01**	5.0	
*UL94 V-0 MATERIAL AVAILABLE BY SPECIAL ORDER ONLY. TO ORDER REPLACE -01 WITH -19.		
** AVAILABLE BY SPECIAL ORDER ONLY		

INFORMATION CONTAINED IN THIS DOCUMENT IS CONFIDENTIAL TO RICHCO INTERNATIONAL Co. Ltd. AND MAY NOT BE DISCLOSED OR REPRODUCED IN WHOLE OR PART WITHOUT THEIR WRITTEN CONSENT.

RICHCO, INC. WWW.RICHCO-INC.COM	ALL DIMENSIONS IN mm GENERAL TOLERANCES ±0.25 UNLESS OTHERWISE STATED 1 DECIMAL PLACE ± 2 DECIMAL PLACES ± ANGULAR ±1°	THIRD ANGLE
---	---	-----------------

MATERIAL: See table		COLOUR: See table	
DESCRIPTION: FLAT TIE HOLDER		PART No: See Table	
DRG No: 011-023	NPR No: XXXX-XXX	SHEET SIZE A4	
DRN SF	DATE 18/02/11	CHKD JK	DATE 18/02/11
SCALE NTS	SHEET No. 1 OF 1		