

A B C D E F

NOTES:
 1) STANDARD PACK QUANTITY:1000.
 2) ALL PRIMARYDIMENSIONS IN mm,
 SECONDARY DIMENSIONS IN INCHES.

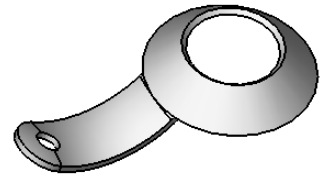

REV.	MODIFICATION.	DATE	DRN
A	PROPOSAL DRAWING	28/07/03	I.C
01	PRODUCTION RELEASE	17/12/03	I.C
02	PACK SIZE WAS 1000	19/08/04	NJB
03	SCN 2004-084	01/09/04	NJB
04	PART NO. UPDATED	02/09/04	NJB
05	SCN 2004-085	03/09/04	NJB
06	ECN 06-262	13/12/06	SF
07	ECN 07-219	06/12/07	NJB
08	CO2010161	27/03/08	SF

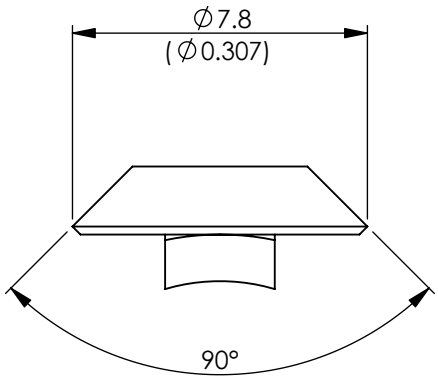
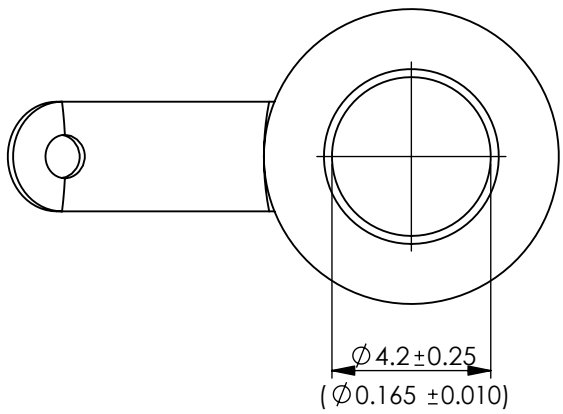
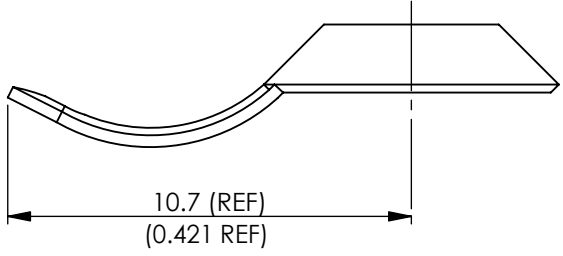

Notes:

- 1) Material and RMS numbers are as follows:
 .03 thick Brass (RMS-373)
 Tin Plating (RMS-246)

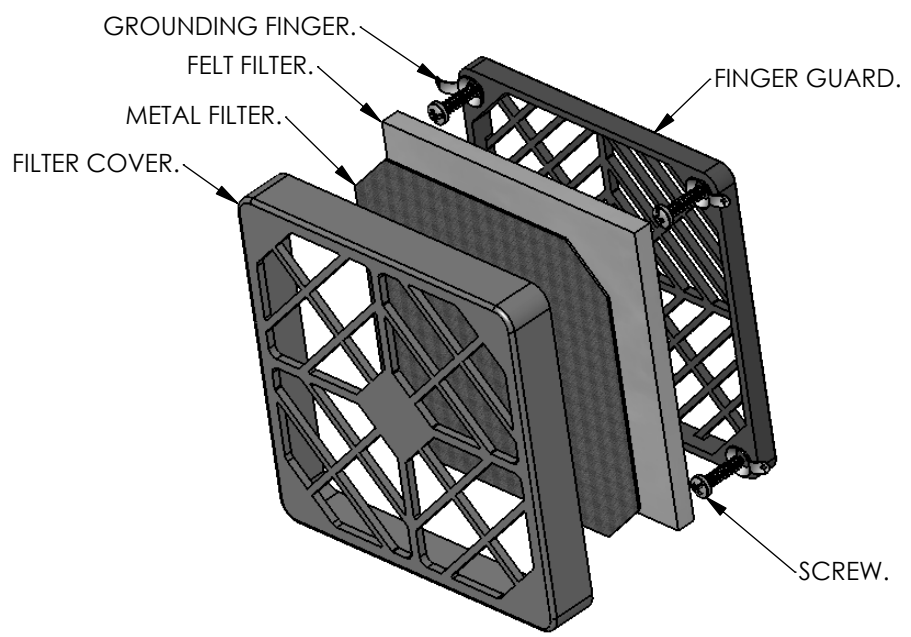

TYPICAL APPLICATION VIEW.

INFORMATION CONTAINED IN THIS DOCUMENT IS CONFIDENTIAL TO RICHCO INTERNATIONAL Co. Ltd. AND MAY NOT BE DISCLOSED OR REPRODUCED IN WHOLE OR PART WITHOUT THEIR WRITTEN CONSENT

	METRIC GENERAL TOLERANCES ±0.40 ARE PRIMARY UNLESS OTHERWISE STATED 1 DECIMAL PLACE ± 2 DECIMAL PLACES ± ANGULAR ±1°
	IMPERIAL GENERAL TOLERANCES ±0.015 ARE FOR REFERENCE UNLESS OTHERWISE 1 DECIMAL PLACE ± 2 DECIMAL PLACES ± ANGULAR ±1°

MATERIAL: SEE NOTES		COLOUR:	
TITLE: GROUNDING FINGER		PART No: FG-1	
DRG No: 2003-280	NPR REF: 2003-284		SIZE A4
DRN I.C	DATE 28/07/03	CHKD NJB	DATE 01/09/04
SCALE 5:1		SHEET No 1 OF 1	

A B C D E F FORM No 0145/01