

REV.	MODIFICATION.	DATE	DRN
01	PRODUCTION RELEASE	20/04/12	SF

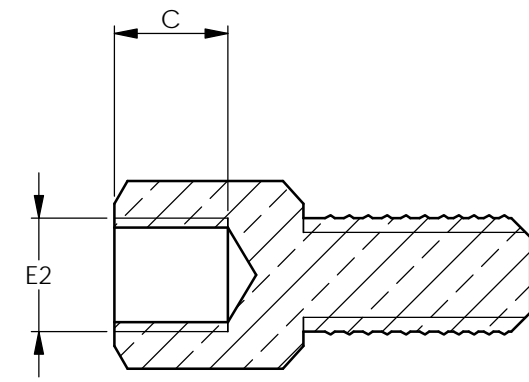
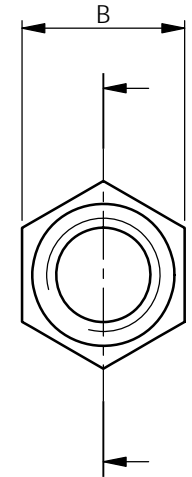
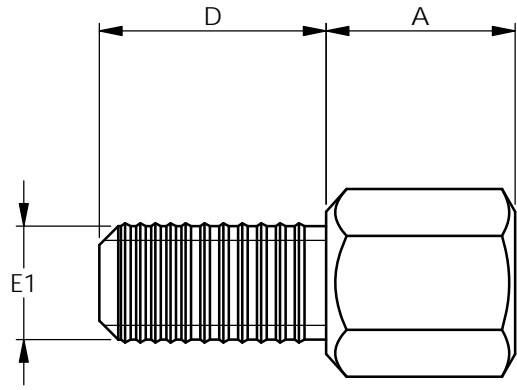
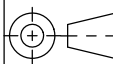

PART No	A	B	C	D	E1	E2	MATERIAL
308101040050	5	5	3	6	M3	M3	BRASS (RMS-276) NICKEL PLATING (RMS-234)
308103040050			3.5		#4-40	M3	
308102040050			3		M3	#4-40	
308104040050			3.5		#4-40	#4-40	
308201040050			3	8	M3	M3	
308203040050			3.5		#4-40	M3	
308202040050			3		M3	#4-40	
308204040050			3.5		#4-40	#4-40	
308301040050			3	12	M3	M3	
308302040050			3		M3	#4-40	
308304040050			3.5		#4-40	#4-40	
308101041152			3		M3	M3	
308103041152			3.5	6	#4-40	M3	
308102041152			3		M3	#4-40	
308104041152			3.5		#4-40	#4-40	
308201041152			3		8	M3	
308203041152			3.5	#4-40		M3	
308202041152			3	M3		#4-40	
308204041152			3.5	#4-40		#4-40	
308301041152			3	12	M3	M3	
308302041152	3	M3	#4-40				
308304041152	3.5	#4-40	#4-40				

INFORMATION CONTAINED IN THIS DOCUMENT IS CONFIDENTIAL TO RICHCO INTERNATIONAL Co. Ltd. AND MAY NOT BE DISCLOSED OR REPRODUCED IN WHOLE OR PART WITHOUT THEIR WRITTEN CONSENT.

RICHCO, INC. WWW.RICHCO-INC.COM	ALL DIMENSIONS IN mm GENERAL TOLERANCES ± 0.25 UNLESS OTHERWISE STATED 1 DECIMAL PLACE \pm 2 DECIMAL PLACES \pm ANGULAR $\pm 1^\circ$	THIRD ANGLE 
---	--	--

MATERIAL: SEE TABLE		COLOUR:	
DESCRIPTION: D-SUB MINIATURE SPACER		PART No: SEE TABLE	
DRG No: 012-057	NPR No:	SHEET SIZE A4	
DRN SF	DATE 20/04/12	CHKD TC	DATE 20/04/12
SCALE NTS	SHEET No. 1 OF 1		