

REV.	MODIFICATION.	DATE	DRN
01	PRODUCTION RELEASE	24/05/11	SF
02	CO2011158	22/06/11	SF
03	CO2011182	01/08/11	SF

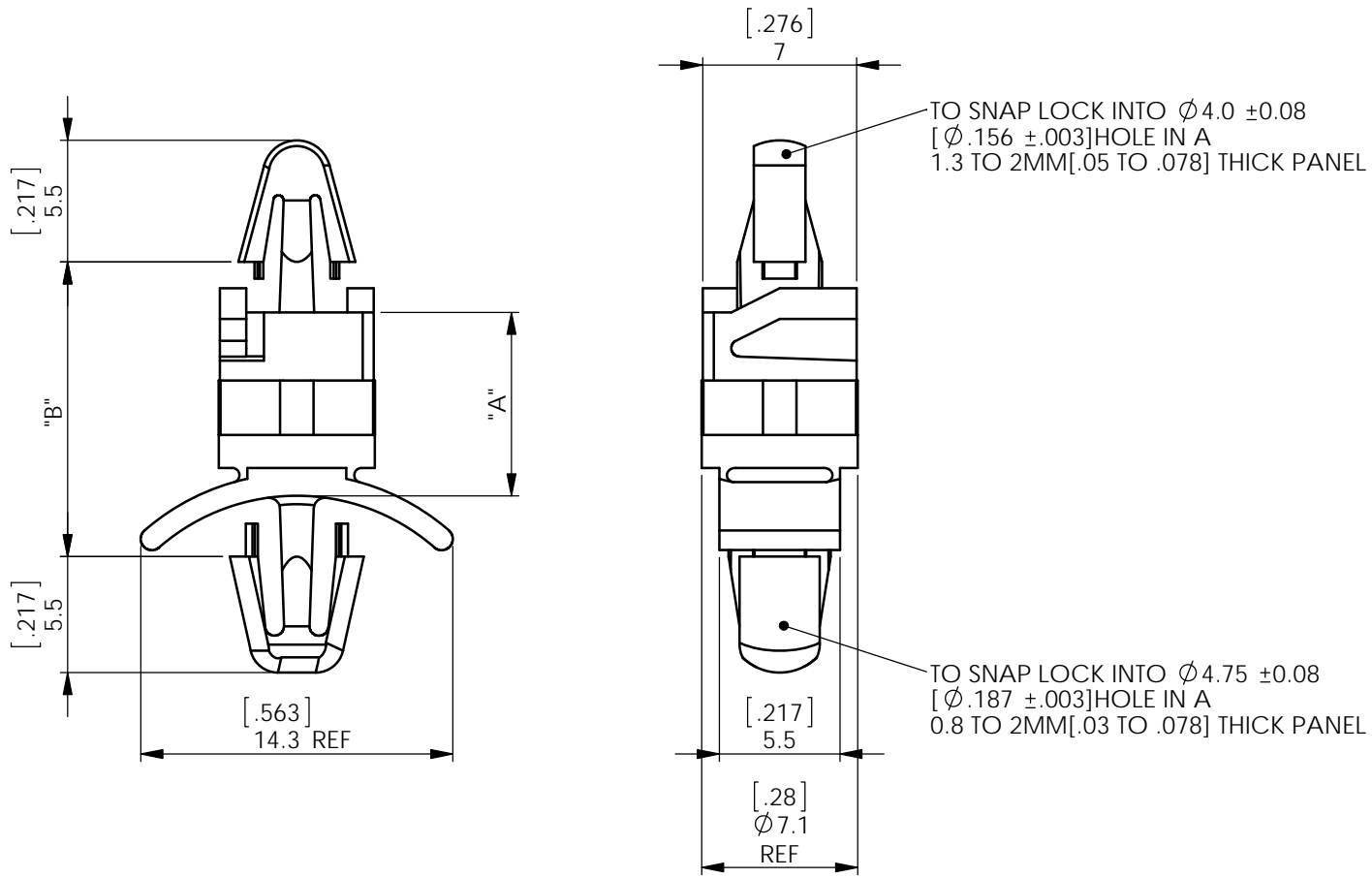

ALTERNATE UNITS FOR REFERENCE ONLY

INFORMATION CONTAINED IN THIS DOCUMENT IS CONFIDENTIAL TO RICHCO INTERNATIONAL Co. Ltd. AND MAY NOT BE DISCLOSED OR REPRODUCED IN WHOLE OR PART WITHOUT THEIR WRITTEN CONSENT.

RICHCO, INC.
 WWW.RICHCO-INC.COM

ALL DIMENSIONS IN mm
 GENERAL TOLERANCES ± 0.25
 UNLESS OTHERWISE STATED
 1 DECIMAL PLACE ± 0.25
 2 DECIMAL PLACES ± 0.10
 ANGULAR $\pm 1^\circ$

THIRD ANGLE

MATERIAL:
 SEE TABLE

COLOUR:
 NATURAL

DESCRIPTION:
 DUAL LOCKING CIRCUIT BOARD
 SUPPORT TYPE 4

PART No:
 DLCBS4

DRG No:
 011-058

PROJECT NUMBER:
 EU10-0005

SHEET SIZE
 A4

DRN
 SF

DATE
 24/05/11

CHKD
 TC

DATE
 24/05/11

SCALE
 NTS

SHEET No.
 1 OF 1

NYLON 6/6 UL94 V-2 (RMS-01)	NYLON 6/6 UL94 V-0 (RMS-19)	"A" STANDOFF HEIGHT ± 0.4	"B" (REF)
DLCBS4-3.5-01	DLCBS4-3.5-19	5.5 [.217]	10.8 [.425]
DLCBS4-4-01	DLCBS4-4-19	6.1 [.240]	11.4 [.449]
DLCBS4-5-01	DLCBS4-5-19	9.1 [358]	14.4 [.567]
DLCBS4-6-01	DLCBS4-6-19	12.4 [.488]	17.7 [.697]
DLCBS4-8-01	DLCBS4-8-19	18.8 [.740]	24.1 [.949]
DLCBS4-10-01	DLCBS4-10-19	21.9 [.862]	27.2 [1.071]