

A B C D E F

REV.	MODIFICATION.	DATE	DRN
01	NEW DWG, ECN 07-233	11/12/07	SF
02	CO2010267	07/07/08	SF
03	CO2010823	17/09/09	OW
04	CO2010945	22/06/10	SF
05	CO2011253	12/04/12	SF

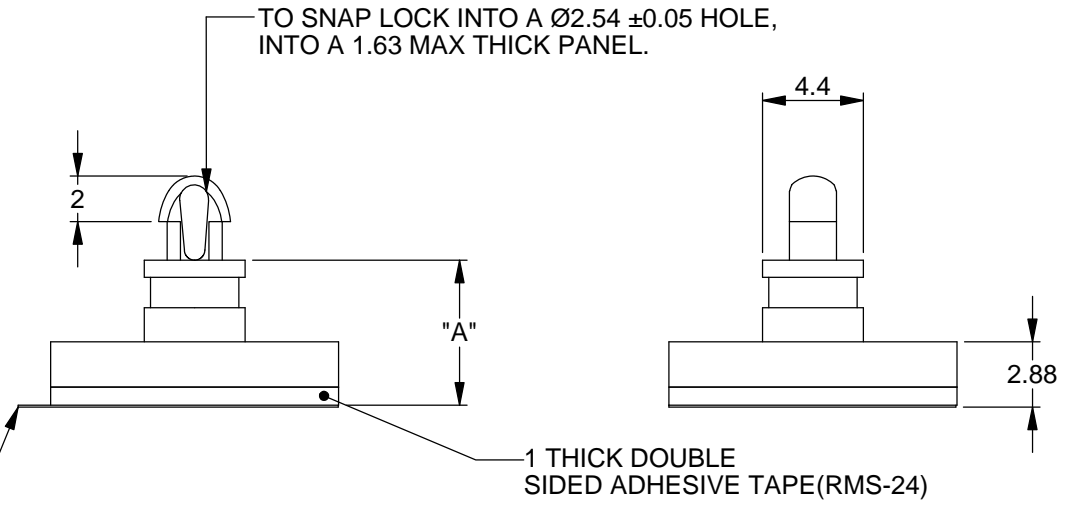
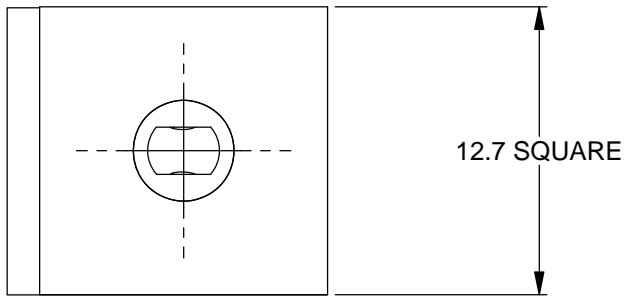

TYPICAL RELEASE TAB LOCATION

NOTES

- 1) METRIC PRIMARY UNITS:mm
- 2) ADHESIVE / URETHANE FOAM TAPE (RMS-24), PE LINER.
- 3) PARTS ALSO AVAILABLE WITHOUT TAPE. TO ORDER REMOVE 'A2' FROM PART No., & SUBTRACT 1 FROM 'A' DIMENSION.
- 4) THE COLOUR OF THE ADHESIVE LINER MAY VARY. THIS WILL NOT AFFECT THE TECHNICAL PROPERTIES OF THE PART.

INFORMATION CONTAINED IN THIS DOCUMENT IS CONFIDENTIAL TO RICHCO INTERNATIONAL Co. Ltd. AND MAY NOT BE DISCLOSED OR REPRODUCED IN WHOLE OR PART WITHOUT THEIR WRITTEN CONSENT.

MATERIAL NYLON 6/6 UL94 V2(RMS-01)	MATERIAL NYLON 6/6 UL 94 V0(RMS-19)	"A" DIM
CBSBT-3-01A2	CBSBT-3-19A2	4.8
CBSBT-4-01A2	CBSBT-4-19A2	6.4
CBSBT-5-01A2	CBSBT-5-19A2	7.9
CBSBT-6-01A2	CBSBT-6-19A2	9.5
CBSBT-7-01A2	CBSBT-7-19A2	11.1
CBSBT-8-01A2	CBSBT-8-19A2	12.7
CBSBT-9-01A2	CBSBT-9-19A2	14.3
CBSBT-10-01A2	CBSBT-10-19A2	15.9

RICHCO, INC.
WWW.RICHCO-INC.COM

GENERAL TOLERANCES ±0.25 [0.010]
UNLESS OTHERWISE STATED
1 DECIMAL PLACE ±
2 DECIMAL PLACES ±
ANGULAR ±1°



MATERIAL: SEE NOTES		COLOUR: NATURAL	
DESCRIPTION: CIRCUIT BOARD SUPPORT ON BASE		PART No: SEE TABLE	
DRG No: 07-140	NPR No: N/A	SHEET SIZE A4	
DRN SF	DATE 10/12/07	CHKD NBr	DATE 11/12/07
SCALE NTS		SHEET No. 1 OF 1	

A B C D E F FORM No. 0145/03