

REV.	MODIFICATION.	DATE	DRN
01	Production Release	20/07/06	TC
02	ECN2007-134	14/08/07	TC
03	CO2010305	04/08/08	MT
04	CO2010314	08/08/08	MT
05	CO2010747	28/07/09	TC
06	CO2010752	29/07/09	OW

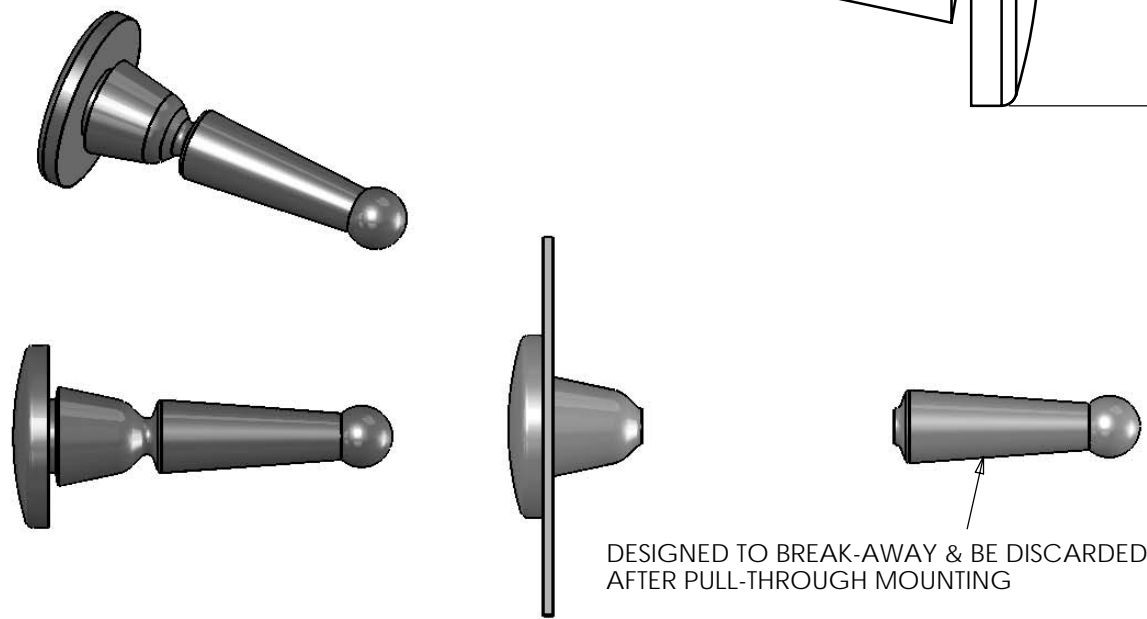
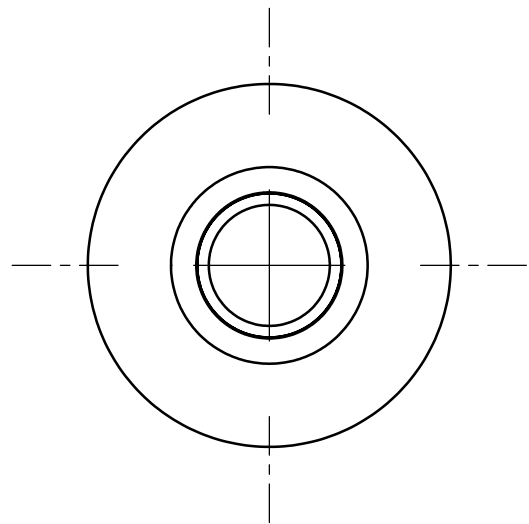
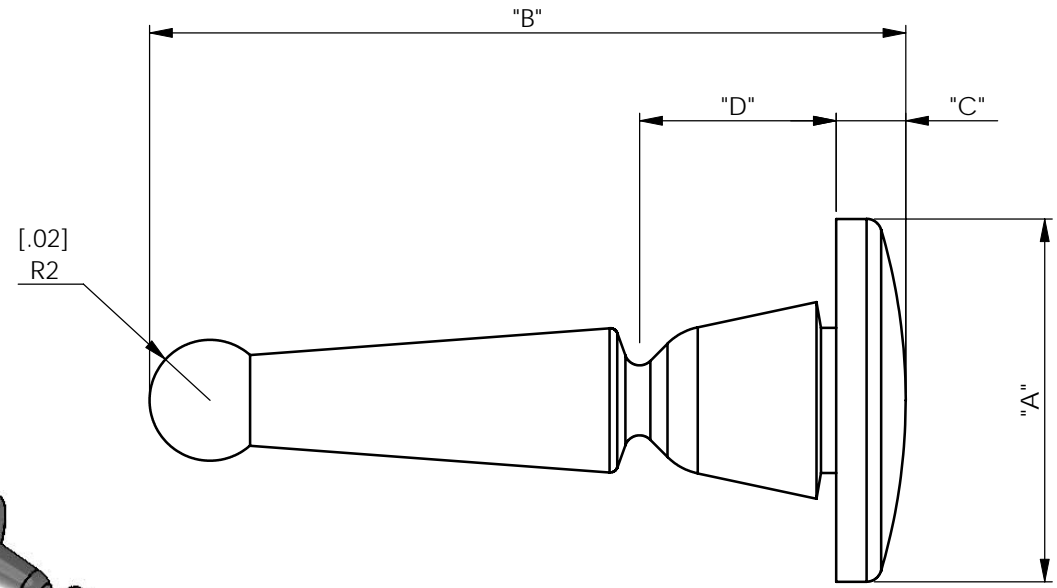

DESIGNED TO BREAK-AWAY & BE DISCARDED AFTER PULL-THROUGH MOUNTING

ALTERNATE UNITS FOR REFERENCE ONLY

INFORMATION CONTAINED IN THIS DOCUMENT IS CONFIDENTIAL TO RICHCO INTERNATIONAL Co. Ltd. AND MAY NOT BE DISCLOSED OR REPRODUCED IN WHOLE OR PART WITHOUT THEIR WRITTEN CONSENT.

RICHCO, INC.
WWW.RICHCO-INC.COM

ALL DIMENSIONS IN mm & [INCHES]
 GENERAL TOLERANCES ±0.25 [.01]
 UNLESS OTHERWISE STATED
 1 DECIMAL PLACE ±0.25 [.01]
 2 DECIMAL PLACES ± 0.10 [.004]
 ANG +/- 1° UNSPEC RADIUS 0.25 [.01]

THIRD ANGLE

PART No	MATERIAL TYPE & HARDNESS	RMS No	"A"	"B"	"C"	"D"	PANEL THICKNESS	HOLE DIAMETER
BAB-1	Silicone Rubber - 40+/- 5 Shore A	RMS-316	12 [.47]	25 [.98]	2.3 [.09]	6.5 [.26]	0.6-0.8 [.024-.031]	5.0-5.4 [.197-.212]
BAB-2	Silicone Rubber - 50+/- 5 Shore A	RMS-364	10 [.39]	20 [.79]	2 [.08]	4.3 [.17]	0.5 [.020]	4.7-5.0 [.185-.197]
BAB-3								

MATERIAL: SEE TABLE				COLOUR: BLACK	
DESCRIPTION: BREAK AWAY BUMPER				PART No: SEE TABLE	
DRG No: 06-078		NPR No: 2005-245		Mass:(g) 0.55g	SHEET SIZE A4
DRN TC	DATE 07/07/05	CHKD TC	DATE 19/07/06	SCALE NTS	SHEET No. 2 OF 2