

## Carbon Kevlar hinges - 50 mm width

Model : 54-7-3602

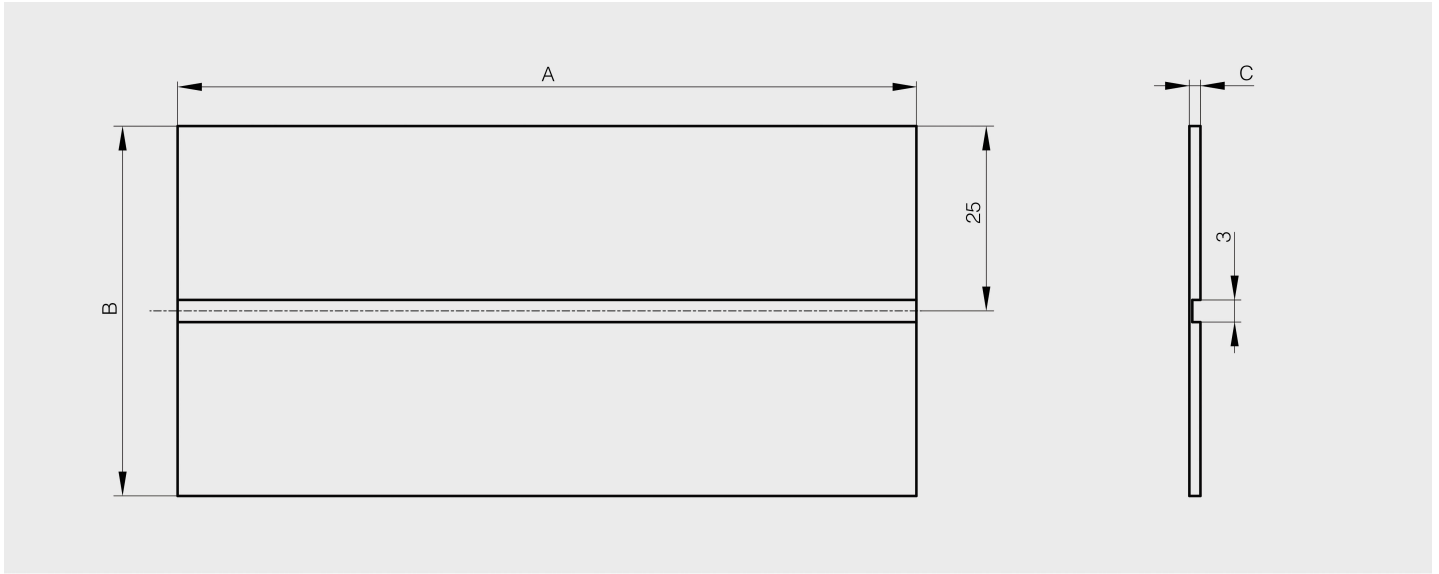

Hinge is constructed of rigid leaves and a flex unit.  
The rigid leaves are woven carbon fibre in an epoxy matrix.  
The Kevlar flex units are impregnated with a flexible urethane.  
Design for bond or screws assembly.  
Part number 54-7-3602 tested to over one million cycles through an 80° arc.  
No metallic component. Ultra light, ultra thin.



Material	carbon / Kevlar
Finish	black
A (length)	50
B (width)	50
C	1.5
Weight (g)	4
Opening angle	270
Material	polymer