

SMTPFSM ReelFast[®] SURFACE MOUNT CAPTIVE PANEL SCREWS

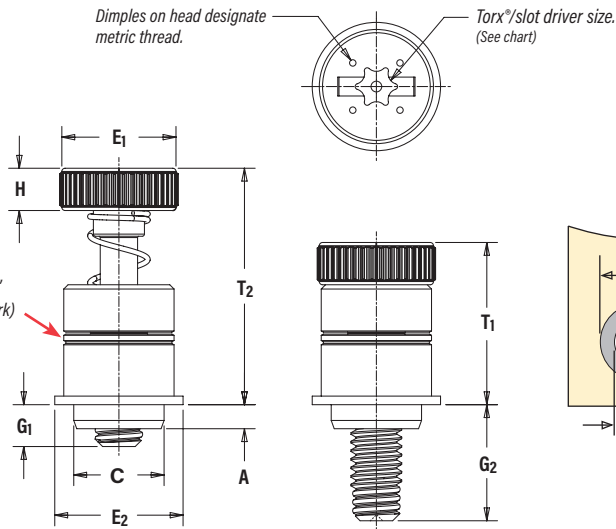

PART NUMBER DESIGNATION

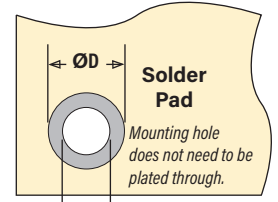
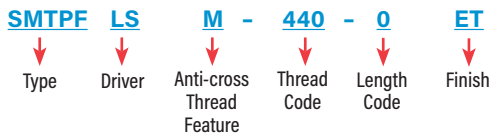

All dimensions are in inches.

UNIFIED	Thread Size	Type	Thread Code	Screw Length Code	A (Shank) Max.	Min. Sheet Thickness	C Max.	E ₁ ±.010	E ₂ Nom	G ₁ ±.025	G ₂ ±.025	H ±.010	T ₁ Nom.	T ₂ Nom.	ØK Hole Size in Sheet +.003 -.000	ØD Min. Solder Pad	Driver Size
	.112-40 (#4-40)	SMTPF ^{LS} M	440	0	.063	.063	.215	.280	.300	.040	.210	.100	.38	.55	.220	.340	T15
.138-32 (#6-32)	SMTPF ^{LS} M	632	0	.063	.063	.247	.310	.320	.040	.240	.100	.42	.62	.252	.400	T15	
			1							.100	.300						

All dimensions are in millimeters.

METRIC	Thread Size	Type	Thread Code	Screw Length Code	A (Shank) Max.	Min. Sheet Thickness	C Max.	E ₁ ±0.25	E ₂ Nom	G ₁ ±0.64	G ₂ ±0.64	H ±0.25	T ₁ Nom.	T ₂ Nom.	ØK Hole Size in Sheet +0.08	ØD Min. Solder Pad	Driver Size
	M3 x 0.5	SMTPF ^{LS} M	M3	0	1.6	1.6	5.46	7	7.6	1	5.3	2.5	9.6	14	5.6	8.6	T15
1										2.5	6.8						
M3.5 x 0.6	SMTPF ^{LS} M	M3.5	0	1.6	1.6	6.27	7.9	8.13	1	6.1	2.5	10.7	15.7	6.4	10.2	T15	
			1							2.5	7.62						

NUMBER OF PARTS PER REEL

Thread Size	Parts Per Reel
440	200
632	150
M3	200
M3.5	150

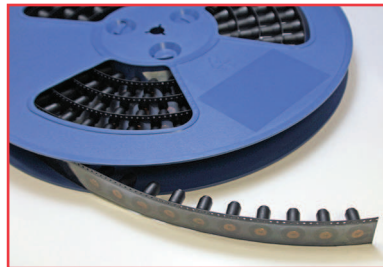

Packaged on 330 mm recyclable reels. Tape width is 24 mm. Supplied with polyimide patch for vacuum pick up. Reels conform to EIA-481.

