

ITEM	COLOUR	MAX CABLE BUNDLE DIA	L	W	TENSILE LBS/kg
460177	Natural	25	100	2.5	18/8

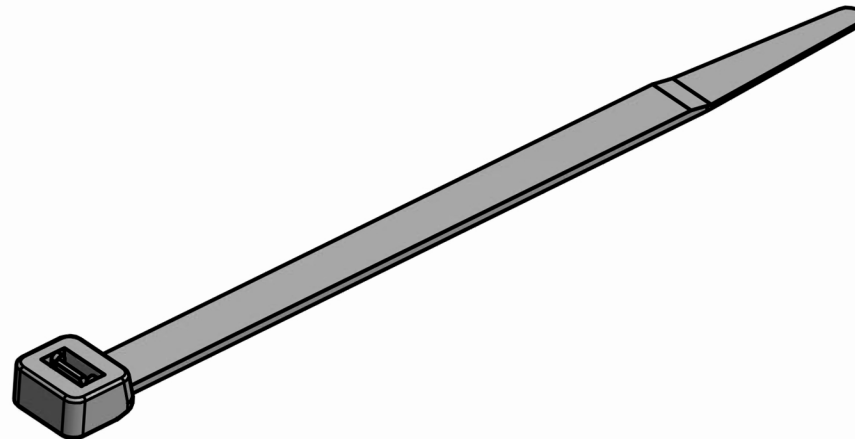

UNLESS OTHERWISE STATED

ALL DIMENSIONS IN mm

DO NOT SCALE

LINEAR TOLERANCE

THIRD ANGLE PROJECTION

SIZE	(0)	(0.0)	(0.00)
0-10mm	±0.5	±0.15	±0.10
10-30mm	±0.5	±0.20	±0.15
30-50mm	±0.5	±0.30	±0.20
50-100mm	±0.8	±0.50	±0.25
100-200mm	±1.5	±0.80	±0.40
200-300mm	±2.0	±1.20	±0.80
300-500mm	±3.0	±2.00	±1.00
+500mm	±5.0	±3.00	±1.50

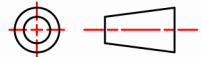

ANGULAR TOLERANCE ±0.5 DEGREES
UNSPECIFIED RADII 0.25mm
DRAFT ANGLE 0.5 DEGREES

ORG SCALE 1:1

MATERIAL **NYLON**

ITEM No. **460177**

TITLE

STANDARD CABLE TIES