

FASTON A SCARICA DI CONDENSATORI

CAPACITOR DISCHARGE FASTON

FLACHSTECKER FÜR SPITZENZÜNDUNG

COSSE PAR DÉCHARGE DE CONDENSATEURS

FASTON PARA SOLDAR CON DESCARGA

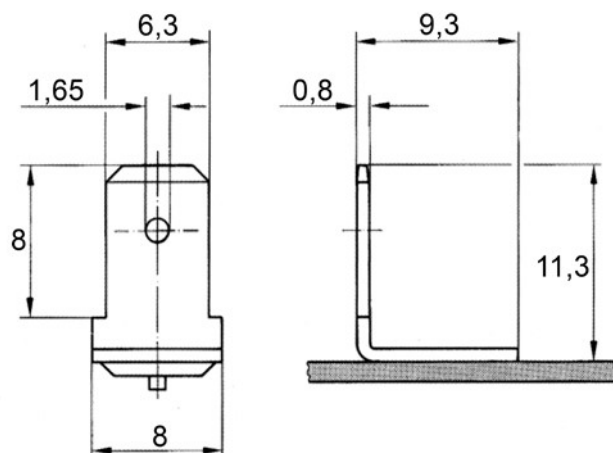

PRIMA DELLA SALDATURA
BEFORE WELDING
VOR DEM SCHWEISSEN
AVANT SOUDAGE
ANTES DE SOLDAR

DOPO LA SALDATURA
AFTER WELDING
NACH DEM SCHWEISSEN
APRÈS SOUDAGE
DESPUES DE SOLDAR

FASTON SINGOLO
SINGLE FASTON
FLACHSTECKER
COSSE SIMPLE
FASTON SIMPLE



ACCIAIO 4.8 RAMATO STEEL 4.8 COPPER PLATED STAHL 4.8 VERKUPFERT ACIER 4.8 CUIVRÉ ACERO 4.8 COBREADO	ACCIAIO INOX A2-50 STAINLESS STEEL A2-50 ROSTFREIER STAHL A2-50 INOX A2-50 INOX A2-50	ALLUMINIO AIMg3 ALUMINIUM AIMg3 ALUMINIUM AIMg3 ALUMINIUM AIMg3 ALUMINIO AIMg3	OTTONE CuZn37 BRASS CuZn37 MESSING CuZn37 LAITON CuZn37 LATÓN CuZn37
Codice Code	Codice Code	Codice Code	Codice Code
03ARFS	03IXFS	03ALFS	03CUFS

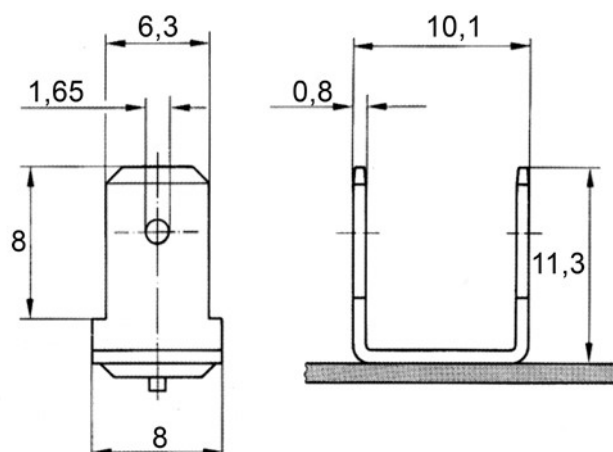

PRIMA DELLA SALDATURA
BEFORE WELDING
VOR DEM SCHWEISSEN
AVANT SOUDAGE
ANTES DE SOLDAR

DOPO LA SALDATURA
AFTER WELDING
NACH DEM SCHWEISSEN
APRÈS SOUDAGE
DESPUES DE SOLDAR

FASTON DOPPIO
DOUBLE FASTON
DOPPEL FLACHSTECKER
COSSE DOUBLE
FASTON DOBLE



ACCIAIO 4.8 RAMATO STEEL 4.8 COPPER PLATED STAHL 4.8 VERKUPFERT ACIER 4.8 CUIVRÉ ACERO 4.8 COBREADO	ACCIAIO INOX A2-50 STAINLESS STEEL A2-50 ROSTFREIER STAHL A2-50 INOX A2-50 INOX A2-50	ALLUMINIO AIMg3 ALUMINIUM AIMg3 ALUMINIUM AIMg3 ALUMINIUM AIMg3 ALUMINIO AIMg3	OTTONE CuZn37 BRASS CuZn37 MESSING CuZn37 LAITON CuZn37 LATÓN CuZn37
Codice Code	Codice Code	Codice Code	Codice Code
03ARFD	03IXFD	03ALFD	03CUFD