

## Self-aligning brackets

square flanged, technopolymer

### BRACKET

Glass-fibre reinforced polyamide based (PA) technopolymer, black colour, matte finish.

### BUSHINGS AND WASHERS

AISI 304 stainless steel.

### BEARING

High quality with traceability codes. Chrome steel.

### LUBRICATOR

Nickel-plated brass.

### PACKING RINGS

NBR rubber.

### COVER

Glass-fibre reinforced polypropylene based (PP) technopolymer, RAL 7015 grey colour, matte finish.  
Closed cap for head bracket or for pass-through shafts.

### STANDARD EXECUTIONS

- **UCF-T**: head bracket with closed cover.
- **UCF-P**: bracket for pass-through shaft with drilled cover and NBR rubber packing ring for rotating shafts.

### FEATURES AND APPLICATIONS

Overall dimensions are in compliance with ISO 3228.  
A system of completely sealed packing rings assures the protection of the bearing from dirt ingress.  
Max shaft misalignment = 2,5°.



### INSTRUCTIONS OF USE

Assembly with shafts without end stops. For optimum operation, we recommend periodic lubrication with a common grease resistant to high temperatures and oxidation.

### SPECIAL EXECUTIONS ON REQUEST

- AISI 440C stainless steel bearing.
- Bearing in inch sizes.
- Brackets for shafts with diameters in different sizes.
- Brackets in polypropylene based (PP) technopolymer, packing rings and oil seal type VITON®\*.

\* Registered trademark by DuPont Dow Elastomers.

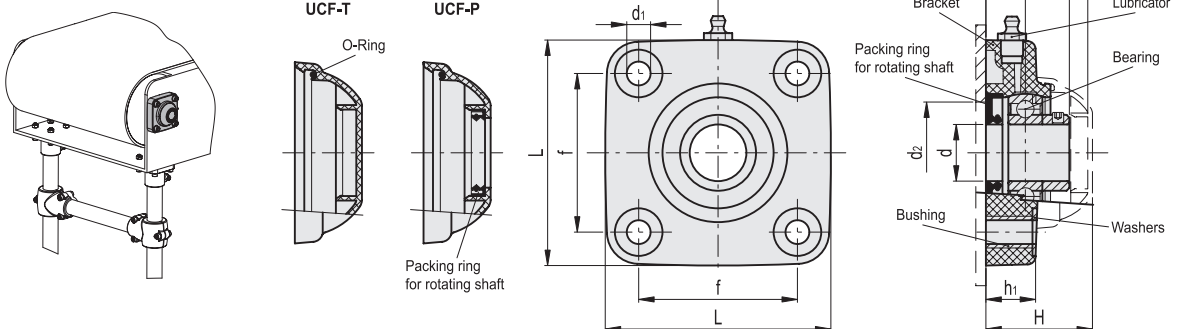

Code	Description	d	d1	d2 min	d2 max	H	L	f	h1	h2	h3	h4	Bearing static load [N]	Bearing dynamic load [N]	Bracket load [N]	⚖️
419551	UCF.205-A-25-T	25	10.5	45	50	49	99	70	22	36	47	17	7000	14000	17000	445
419561	UCF.206-A-30-T	30	10.5	50	60	56	113	83	26	41	54	20	11000	19000	17000	511
419531	UCF.205-A-25-P	25	10.5	45	50	49	99	70	22	36	-	17	7000	14000	17000	452
419541	UCF.206-A-30-P	30	10.5	50	60	56	113	83	26	41	-	20	11000	19000	17000	518