

SQT.

Angles
for profile structures

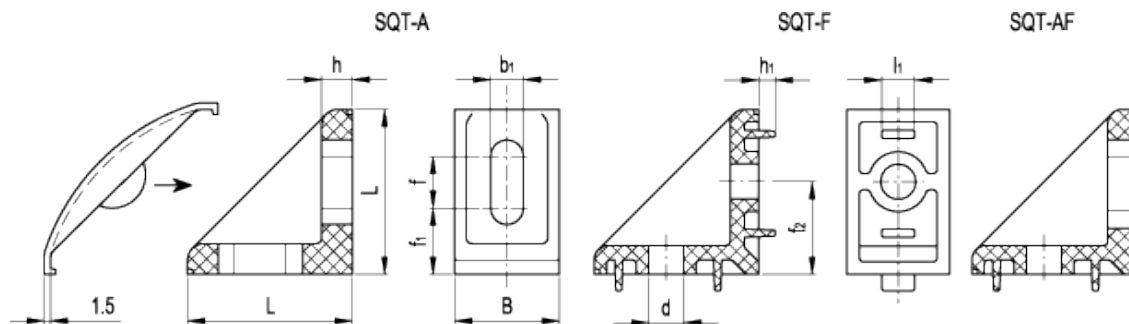

FM Design



technical informations

Material

Glass-fibre reinforced polyamide-based technopolymer (PA). Resistant to solvents, oils, greases and other chemical agents.

Colour

Grey similar to RAL 7046, matte finish.

Assembly

Execution A: with two slots for M8 screws, not supplied.

Execution F: with two holes for M8 screws, not supplied, with centering slides.

Execution AF: with slot and hole for M8 screws, not supplied, with centering slides.

In case of assembly with two screws in the slot, we suggest you to use screws type UNI 9327 DIN 7984.

Features and applications

SQT. connecting angles are particularly suitable for the assembly of industrial components such as metal profiles, protections and working planes. It can be used as a clamping element to assemble, in a very easy way, structures made out of aluminium profiles to protect and guarantee the safety of the operator during normal work on equipment, machines, etc....

The shape, the sections and the material used to produce these connection angles guarantee high mechanical characteristics, dimensional stability and high resistance to temperature.

Accessories on request

In order to avoid any deposit of dirt and dust on the connection angles, polyester based technopolymer (PBT) covers series CO.SQT in grey colour similar to RAL 7046, semi-glossy finish, are available on request, sold separately (see table).

Application example

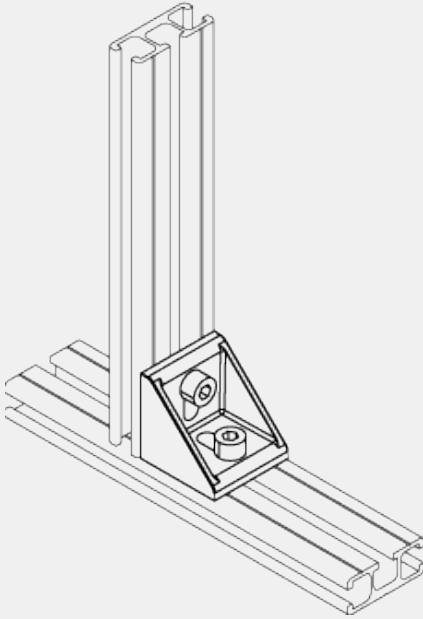

Technical Data

For the correct use of the connecting angles, all the three conditions (F), (F*I), (Maximum tightening torque) must be verified.

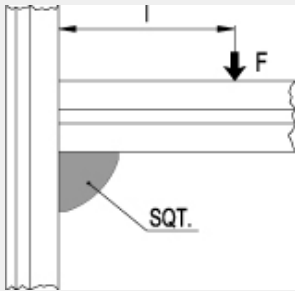

Standard Elements		Main dimensions					Fitting					Weight
Code	Description	L	B	h	h ₁	l ₁	b ₁	f	f ₁	d	f ₂	g
156111	SQT.40-18-A-8	40	18.5	7	-	-	8.5	13	14.5	-	-	12
156113	SQT.40-18-F-8	40	18.5	7	4	8	-	-	-	8.5	22.5	14
156115	SQT.40-18-AF-8	40	18.5	7	4	8	8.5	13	14.5	8.5	22.5	13
156121	SQT.40-25-A-8	40	25	7	-	-	8.5	13	14.5	-	-	18
156123	SQT.40-25-F-8	40	25	7	4	8	-	-	-	8.5	22.5	20
156125	SQT.40-25-AF-8	40	25	7	4	8	8.5	13	14.5	8.5	22.5	19
156131	SQT.43-43-A-8	43	43	8	-	-	8.5	13	17	-	-	32
Code	Description	Covers for										
156101	CO.SQT.40-18	SQT.40-18										
156103	CO.SQT.40-25	SQT.40-25										
156105	CO.SQT.43-43	SQT.43-43										

Standard Elements		F	F • l	Maximum tightening torque
Code	Description	[N]	[Nm]	[Nm]
156111	SQT.40-18-A-8	<600	<25	5
156113	SQT.40-18-F-8	<600	<25	5
156115	SQT.40-18	<600	<25	5
156121	SQT.40-25-A-8	<700	<30	5
156123	SQT.40-25-F-8	<700	<30	5
156125	SQT.40-25	<700	<30	5
156131	SQT.43-43	<750	<35	5



STANDARD MACHINE ELEMENTS WORLDWIDE