

# SH.N

Spherical knobs with magnifying lens

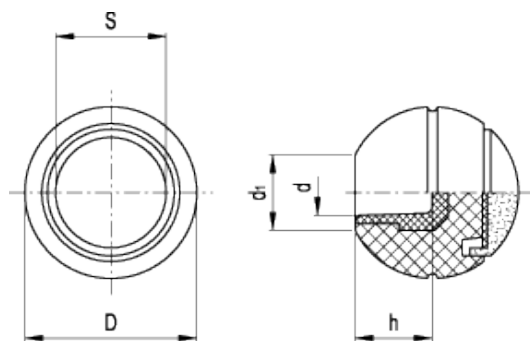

ELESA Original design



## technical informations

### Material

Phenolic based (PF) Duroplast. Resistant to solvents, oils, greases and other chemical agents.

### Colour

Black, glossy finish with equatorial groove.

### Magnifying lens

Transparent polyamide based (PA-T) technopolymer. Resistant to solvents, oils, greases, petrol and other chemical agents (avoid contact with alcohol). Press-fit assembly. It improves the visibility of the labels.

### Assembly

Glass-fibre reinforced polyamide based (PA) technopolymer self-locking boss, plain blind hole. The elastic coupling by press-fit assembly on h9 tolerance drawn stock bars, is not affected by vibrations and prevents the handle from slipping off (see [Technical Data](#) ).

*Accessories on request*

Self-adhesive labels [MA](#), with standard marks and symbols to be ordered separately.

### Assembly instructions

1. Fit the handle, without the magnifying lens, onto slight chamfered shaft end and push as far as possible by hand or by means of a small press. Alternatively it is possible to tap the handle with a plastic or wooden mallet until firmly in place. In this case we strongly recommend to use a cloth or other suitable soft material over the product to avoid any surface damage.
2. Stick the self-adhesive label (printed on the adhesive side) to the inner surface of the magnifying lens by pressing from the centre to the external side to avoid air bubbles. Assemble the magnifying lens to the handle face recess by gently tapping with a wooden or plastic mallet, until firmly in place. The label is therefore protected by the watertight magnifying lens.

Standard Elements		Main dimensions			Mounting hole		Weight
Code	Description	D	d <sub>1</sub>	S	d	h	g
55001	SH.35 N-8	35	15	20	8	14	27
55011	SH.35 N-10	35	15	20	10	18	26
55101	SH.40 N-10	40	18	25	10	18	40
55111	SH.40 N-12	40	18	25	12	21	38
55201	SH.45 N-12	45	21	25	12	21	60
55211	SH.45 N-14	45	21	25	14	24	58



ELESA and GANTER models all rights reserved in accordance with the law. Always mention the source when reproducing our drawings.

STANDARD MACHINE ELEMENTS WORLDWIDE