

## Pressurised breather caps

with double valve and vandal-proof device,  
technopolymer

### MATERIAL

- Cover: polyamide based (PA) technopolymer, black colour, matte finish. Graphic symbol "double valve".
- Threaded connector: acetal based technopolymer (POM), black colour, matte finish.

### PACKING RING

NBR synthetic rubber.

### OVERPRESSURE VALVE

Technopolymer with NBR synthetic rubber O-ring and stainless steel spring.  
Set at around 0.350 bar (on request 0.700 bar).

### SUCTION VALVE

Technopolymer sealing disk with NBR synthetic rubber O-ring and stainless steel spring.  
Set at around 0.030 bar.

### RING-SHAPED AIR FILTER

"Tech-foam" polyurethane foam mesh (polyester base), air filtration 40  $\mu$ .

### KEY

Acetal resin-based (POM) technopolymer, red colour, with stainless steel anti-intrusion-profile insert. Folding. On request it can be supplied in black colour too.

### MAXIMUM CONTINUOUS WORKING TEMPERATURE

100°C.

### "VANDAL-PROOF" SAFETY DEVICE (ELESA PATENT)

It is especially designed to prevent the cap from being unscrewed without permission. It is provided with a "controlled-torque" mechanism which guarantees the best seal of the packing ring.

### SPECIAL EXECUTIONS ON REQUEST

Flat dipstick, flat section phosphatised steel.

### APPLICATIONS

SFW-VP pressurised breather caps are suitable for material handling equipment, machines for the agriculture sector and in general for those machines which remain unattended.

Thanks to its small dimensions, the key can be kept together with others (e.g. starting key of the engine).



ELESA Original design

## SFW.VP pressurised breather cap functioning in a hydraulic circuit

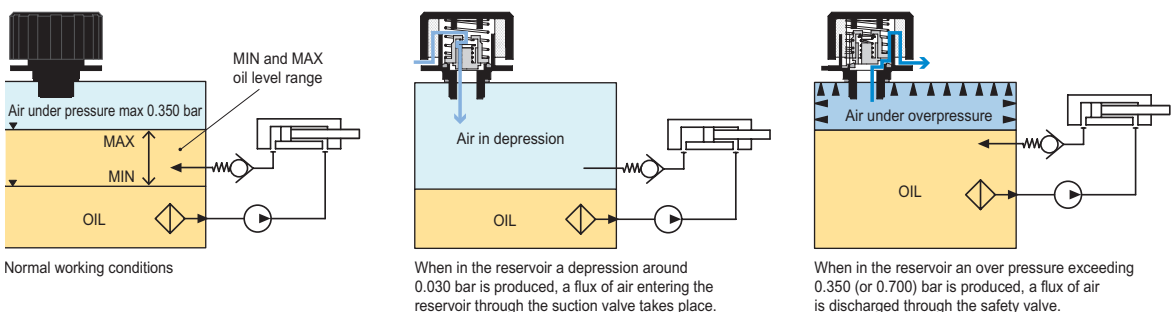

**FEATURES**

The use of SFW-VP pressurised breather cap which create a pressure plenum chamber right above the oil level within tested limit conditions, in order to avoid any reservoir deformation, offers also other advantages (see features of the breather caps type SFW. on page 1712).

**TECHNICAL DATA**

Air flow rate for each model can be determined from the graph calculating the difference between the pressure inside and outside the reservoir.

**"VANDAL-PROOF" SAFETY DEVICE FUNCTIONING**

- Cap screwing.  
 Take out the key and screw the cap clockwise until the friction-click controlled torque mechanism is engaged so that to guarantee the best sealing of the packing ring. The maximum torque is reached at the first mechanism release (click).  
 After that, the cap can neither be screwed (to protect the packing ring) nor unscrewed (to protect the cap from any tampering attempt).  
 WARNING: during screwing the key must not be inserted.  
 - Cap unscrewing.  
 Turn the cap clockwise until one of the two resistance points is reached. Only at one of these two positions the key, which couples the cover to the threaded connector, can be completely inserted and the cap can be unscrewed.

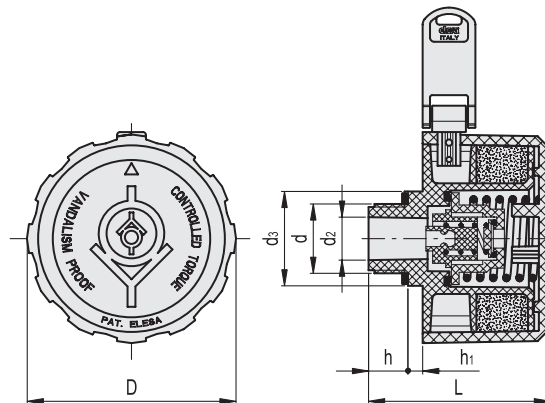
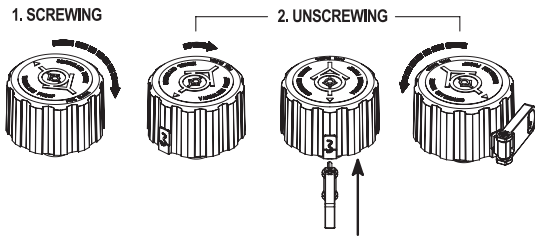
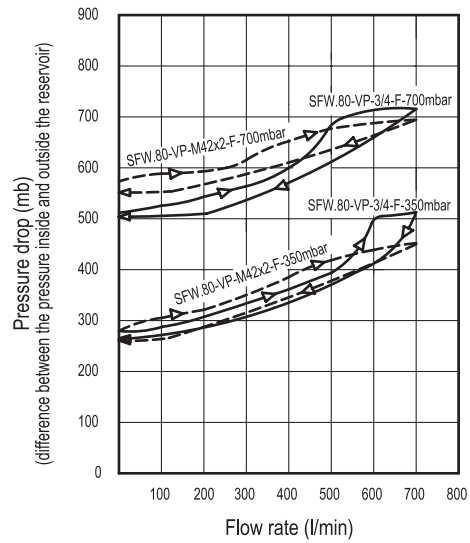

Code	Description	d	D	L	d2	d3	h	h1	ΔP
54961	SFW.80-VP-3/4-F-350mb	G 3/4	80	68	16	36	15	5.5	140
54967	SFW.80-VP-M42x2-F-350mb	M42x2	80	74	32	47	21	4	150

