

## Breather caps

with splash guard and flat dipstick, technopolymer

### COVER

- Polyamide based (PA) technopolymer, semi-matte finish.
- SFP+a.: RAL 2004 orange, marked "OIL".
- SFP+a.....C9: RAL 9005 black colour, marked "OIL".
- SFP+a.....C2-N: RAL 2004 orange, without "OIL" mark.
- SFP+a.....C9-N: RAL 9005 black colour, without "OIL" mark.

### THREADED FITTING

Polyamide based (PA) technopolymer, black colour, semi-matte finish.

### PACKING RING

NBR synthetic rubber.

### FLAT DIPSTICK

Flat section phosphatised steel.  
On request and for sufficient quantities dipstick can be supplied in different lengths and/or complete with MAX-MIN level lines.

### SPLASH GUARD

Technopolymer.

### STANDARD EXECUTIONS

- **SFP+a**: without air filter (black splash guard).
- **SFP+F+a**: D = 31, 42 and 57 with "tech-fill" air filter in zinc-plated steel wire (orange splash guard); D = 70 with "tech-foam" air filter in polyurethane foam mesh (polyester base), air filtration 40 μ (grey splash guard).
- **SFP-BA+F+a**: with "tech-foam" air filter in polyurethane foam mesh (polyester base), air filtration 40 μ (grey splash guard). Zinc-plated steel sheet bayonet.

### MAXIMUM CONTINUOUS WORKING TEMPERATURE

100°C.

### FEATURES AND APPLICATIONS

SFP+a breather caps come complete with splash guard device (ELESA originale design) that prevents oil loss and are particularly suitable for use where oil is violently agitated and could be splashed against the breather cap.



ELESA Original design



### TECHNICAL DATA

Air flow rate for each model can be determined from the graph calculating the difference between the pressure inside and outside the reservoir.

### SPECIAL EXECUTION ON REQUEST

Threaded connector also with NPT thread (National Taper Pipe Thread - ANSI-ASME B1-20) for the codes marked with # in the table.

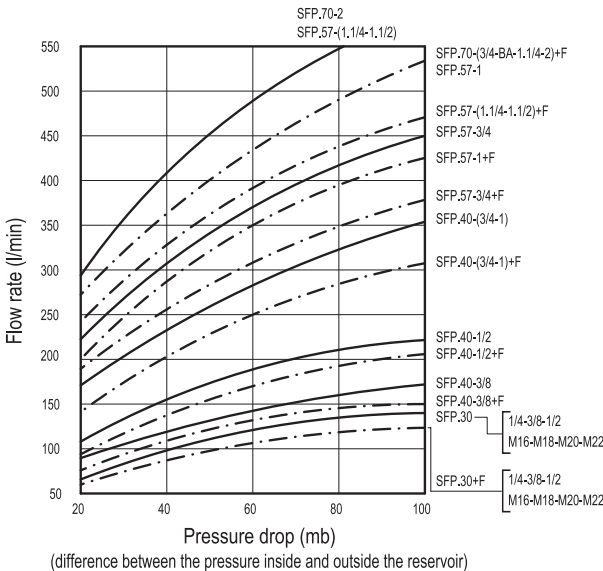

### Operating layout

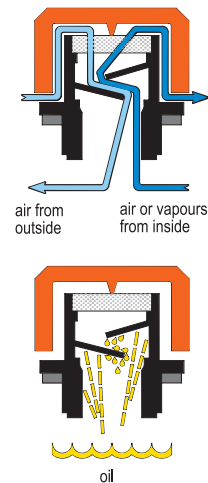

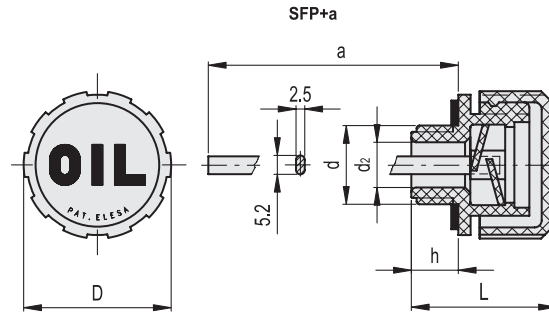

SFP+a

SFP+a

Code	Description	Code	Description	d	D	L	d2	h	a	△
53946	SFP.30-16x1.5+a	53946-C9	SFP.30-16x1.5+a-C9	M16x1.5	31	29.5	10	9.5	188	30
53966	SFP.30-18x1.5+a	53966-C9	SFP.30-18x1.5+a-C9	M18x1.5	31	29.5	10	9.5	188	30
53983	SFP.30-20x1.5+a	53983-C9	SFP.30-20x1.5+a-C9	M20x1.5	31	29.5	12	9.5	188	31
53993	SFP.30-22x1.5+a	53993-C9	SFP.30-22x1.5+a-C9	M22x1.5	31	29.5	12	9.5	188	31
53936	SFP.30-1/4+a	53936-C9	SFP.30-1/4+a-C9	G 1/4	31	29.5	8	9.5	188	30
54011	SFP.30-3/8+a	54011-C9	SFP.30-3/8+a-C9	G 3/8	31	29.5	10	9.5	188	30
54111	SFP.30-1/2+a	54111-C9	SFP.30-1/2+a-C9	G 1/2	31	29.5	12	9.5	188	30
54211	SFP.40-3/4+a	54211-C9	SFP.40-3/4+a-C9	G 3/4	42	36.5	18	11.5	184	42
54311	SFP.40-1+a	54311-C9	SFP.40-1+a-C9	G 1	42	36.5	18	11.5	184	44
54411	SFP.57-1¼+a	54411-C9	SFP.57-1¼+a-C9	G1 1/4	57	44	28	16	184	63
54511	SFP.57-1½+a	54511-C9	SFP.57-1½+a-C9	G1 1/2	57	44	28	16	184	65
54877	SFP.70-2+a	54877-C9	SFP.70-2+a-C9	G 2	70	59	23	17	179	106

SFP+a-N

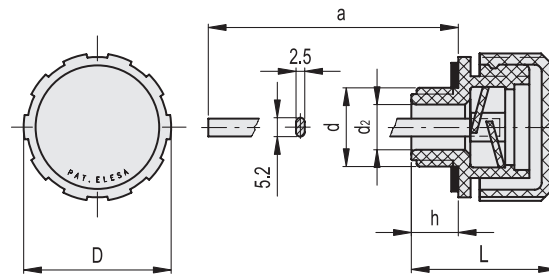

SFP+a-N

SFP+a-N

Code	Description	Code	Description	d	D	L	d2	h	a	△
53946-C2-N	SFP.30-16x1.5+a-C2-N	53946-C9-N	SFP.30-16x1.5+a-C9-N	M16x1.5	31	29.5	10	9.5	188	30
53966-C2-N	SFP.30-18x1.5+a-C2-N	53966-C9-N	SFP.30-18x1.5+a-C9-N	M18x1.5	31	29.5	10	9.5	188	30
53983-C2-N	SFP.30-20x1.5+a-C2-N	53983-C9-N	SFP.30-20x1.5+a-C9-N	M20x1.5	31	29.5	12	9.5	188	31
53993-C2-N	SFP.30-22x1.5+a-C2-N	53993-C9-N	SFP.30-22x1.5+a-C9-N	M22x1.5	31	29.5	12	9.5	188	31
53936-C2-N	SFP.30-1/4+a-C2-N	53936-C9-N	SFP.30-1/4+a-C9-N	G 1/4	31	29.5	8	9.5	188	30
54011-C2-N	SFP.30-3/8+a-C2-N	54011-C9-N	SFP.30-3/8+a-C9-N	G 3/8	31	29.5	10	9.5	188	30
54111-C2-N	SFP.30-1/2+a-C2-N	54111-C9-N	SFP.30-1/2+a-C9-N	G 1/2	31	29.5	12	9.5	188	30
54211-C2-N	SFP.40-3/4+a-C2-N	54211-C9-N	SFP.40-3/4+a-C9-N	G 3/4	42	36.5	18	11.5	184	42
54311-C2-N	SFP.40-1+a-C2-N	54311-C9-N	SFP.40-1+a-C9-N	G 1	42	36.5	18	11.5	184	44
54411-C2-N	SFP.57-1¼+a-C2-N	54411-C9-N	SFP.57-1¼+a-C9-N	G1 1/4	57	44	28	16	184	63
54511-C2-N	SFP.57-1½+a-C2-N	54511-C9-N	SFP.57-1½+a-C9-N	G1 1/2	57	44	28	16	184	65
54877-C2-N	SFP.70-2+a-C2-N	54877-C9-N	SFP.70-2+a-C9-N	G 2	70	59	23	17	179	106



1  
2  
3  
4  
5  
6  
7  
8  
9  
10  
11  
12  
13  
14  
15  
16  
17  
18  
19  
20  
Accessories for hydraulic systems 15

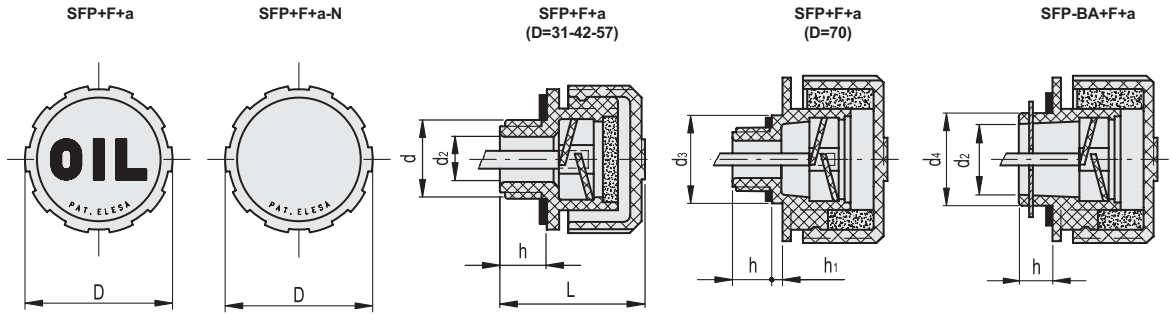

SFP+F+a

SFP+F+a

Code	Description	Code	Description	d	D	L	d2	d3	h	h1	a	△
53956	SFP.30-16x1.5+F+a	53956-C9	SFP.30-16x1.5+F+a-C9	M16x1.5	31	29.5	10	-	9.5	-	188	34
53976	SFP.30-18x1.5+F+a	53976-C9	SFP.30-18x1.5+F+a-C9	M18x1.5	31	29.5	10	-	9.5	-	188	34
53989	SFP.30-20x1.5+F+a	53989-C9	SFP.30-20x1.5+F+a-C9	M20x1.5	31	29.5	12	-	9.5	-	188	32
53999	SFP.30-22x1.5+F+a	53999-C9	SFP.30-22x1.5+F+a-C9	M22x1.5	31	29.5	12	-	9.5	-	188	33
53939	SFP.30-1/4+F+a	53939-C9	SFP.30-1/4+F+a-C9	G 1/4	31	29.5	8	-	9.5	-	188	31
54031	SFP.30-3/8+F+a	54031-C9	SFP.30-3/8+F+a-C9	G 3/8	31	29.5	10	-	9.5	-	188	33
54131	SFP.30-1/2+F+a	54131-C9	SFP.30-1/2+F+a-C9	G 1/2	31	29.5	12	-	9.5	-	188	34
54231	SFP.40-3/4+F+a	54231-C9	SFP.40-3/4+F+a-C9	G 3/4	42	36.5	18	-	11.5	-	184	50
54331	SFP.40-1+F+a	54331-C9	SFP.40-1+F+a-C9	G 1	42	36.5	18	-	11.5	-	184	50
54431	SFP.57-1¼+F+a	54431-C9	SFP.57-1¼+F+a-C9	G1¼	57	44	28	-	16	-	184	75
54531	SFP.57-1½+F+a	54531-C9	SFP.57-1½+F+a-C9	G1½	57	44	28	-	16	-	184	75
54853	SFP.70-3/4+F+a	54853-C9	SFP.70-3/4+F+a-C9	G 3/4	70	63	16	35	15	6	173	100
54863	SFP.70-1¼+F+a	54863-C9	SFP.70-1¼+F+a-C9	G1¼	70	59	23	-	17	-	179	105
54879	SFP.70-2+F+a	54879-C9	SFP.70-2+F+a-C9	G 2	70	59	23	-	17	-	179	110

SFP+F+a-N

SFP+F+a-N

Code	Description	Code	Description	d	D	L	d2	d3	h	h1	a	△
53956-C2-N	SFP.30-16x1.5+F+a-C2-N	53956-C9-N	SFP.30-16x1.5+F+a-C9-N	M16x1.5	31	29.5	10	-	9.5	-	188	34
53976-C2-N	SFP.30-18x1.5+F+a-C2-N	53976-C9-N	SFP.30-18x1.5+F+a-C9-N	M18x1.5	31	29.5	10	-	9.5	-	188	34
53989-C2-N	SFP.30-20x1.5+F+a-C2-N	53989-C9-N	SFP.30-20x1.5+F+a-C9-N	M20x1.5	31	29.5	12	-	9.5	-	188	32
53999-C2-N	SFP.30-22x1.5+F+a-C2-N	53999-C9-N	SFP.30-22x1.5+F+a-C9-N	M22x1.5	31	29.5	12	-	9.5	-	188	33
53939-C2-N	SFP.30-1/4+F+a-C2-N	53939-C9-N	SFP.30-1/4+F+a-C9-N	G 1/4	31	29.5	8	-	9.5	-	188	31
54031-C2-N	SFP.30-3/8+F+a-C2-N	54031-C9-N	SFP.30-3/8+F+a-C9-N	G 3/8	31	29.5	10	-	9.5	-	188	33
54131-C2-N	SFP.30-1/2+F+a-C2-N	54131-C9-N	SFP.30-1/2+F+a-C9-N	G 1/2	31	29.5	12	-	9.5	-	188	34
54231-C2-N	SFP.40-3/4+F+a-C2-N	54231-C9-N	SFP.40-3/4+F+a-C9-N	G 3/4	42	36.5	18	-	11.5	-	184	50
54331-C2-N	SFP.40-1+F+a-C2-N	54331-C9-N	SFP.40-1+F+a-C9-N	G 1	42	36.5	18	-	11.5	-	184	50
54431-C2-N	SFP.57-1¼+F+a-C2-N	54431-C9-N	SFP.57-1¼+F+a-C9-N	G1¼	57	44	28	-	16	-	184	75
54531-C2-N	SFP.57-1½+F+a-C2-N	54531-C9-N	SFP.57-1½+F+a-C9-N	G1½	57	44	28	-	16	-	184	75
54853-C2-N	SFP.70-3/4+F+a-C2-N	54853-C9-N	SFP.70-3/4+F+a-C9-N	G 3/4	70	63	16	35	15	6	173	100
54863-C2-N	SFP.70-1¼+F+a-C2-N	54863-C9-N	SFP.70-1¼+F+a-C9-N	G1¼	70	59	23	-	17	-	179	105
54879-C2-N	SFP.70-2+F+a-C2-N	54879-C9-N	SFP.70-2+F+a-C9-N	G 2	70	59	23	-	17	-	179	110

SFP-BA+F+a

SFP-BA+F+a

Code	Description	Code	Description	D	L	d2	d4	h	a	△
54883	SFP.70-BA+F+a	54883-C9	SFP.70-BA+F+a-C9	70	56	30	39	14	179	100

SFP-BA+F+a-N

SFP-BA+F+a-N

Code	Description	Code	Description	D	L	d2	d4	h	a	△
54883-C2-N	SFP.70-BA+F+a-C2-N	54883-C9-N	SFP.70-BA+F+a-C9-N	70	56	30	39	14	179	100