

Headers for ELEROLL roller tracks

Technopolymer

MATERIAL

Polyamide based technopolymer (PA), black colour.

STANDARD EXECUTIONS

- **RLT-HJ**: joining header.
- **RLT-HE**: end header.

FEATURES AND APPLICATIONS

RLT-HJ header serves to bind tightly two ELEROLL rollers by engaging them (Fig. 1).

RLT-HE header is the end-element of ELEROLL roller tracks (Fig. 2). In addition to being an aesthetic element, the headers represent a safety element for the operator's hands and the handled material.

MOUNTING

Assemble the headers to the end of RLT-AL aluminum profile by means of two UNI 6954 Ø 2,9 x13 self-tapping screws (included in the supply).



FM design

ele:roll®

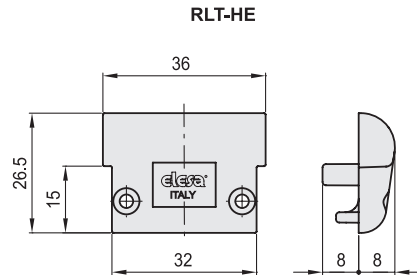
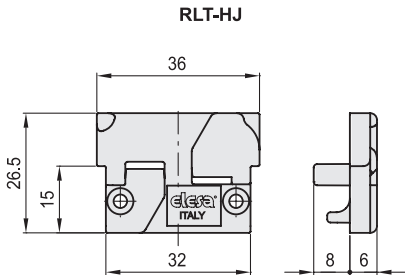
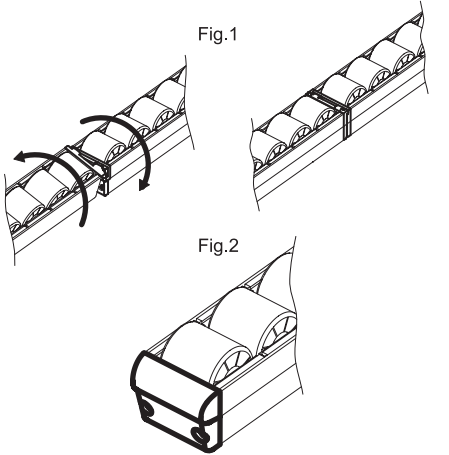

RLT-HJ

Code	Description	
429823	RLT-HJ	4

RLT-HE

Code	Description	
429813	RLT-HE	6

