

Toothed clamping elements

SUPER-technopolymer

MATERIAL

Glass-fibre reinforced polyamide based (PA) SUPER-technopolymer, black colour, matte finish.

STANDARD EXECUTIONS

Central plain pass-through hole and two holes for pins.

- **RDB-F**: front mounting by means of two holes for cylindrical-head screws.
- **RDB-CF**: integral with case, front mounting by means of two holes for cylindrical-head screws.
- **RDB-B**: rear mounting by means of two pass-through holes and two stainless steel hexagonal nuts (included in the supply).
- **RDB-CB**: integral with case, rear mounting by means of two pass-through holes and two stainless steel hexagonal nuts (included in the supply).

FEATURES AND APPLICATIONS

The toothed clamping elements RDB-F and RDB-B, coupled between them or with the executions RDB-CF or RDB-CB, allow to lock the position of two components rotating around an axis. The locking angle is adjustable with a pitch of 6°.

ACCESSORIES ON REQUEST

AISI 301 stainless steel push springs facilitating the detachment of the toothed clamping elements.



Code	Description	d	Max. load [N]	⚖️
51965	ML-RDB.32	23	65	2
51967	ML-RDB.40	29	90	4

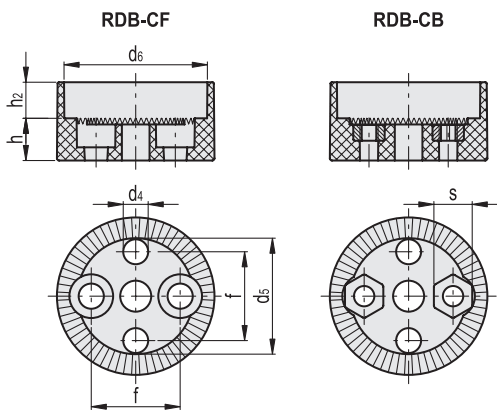
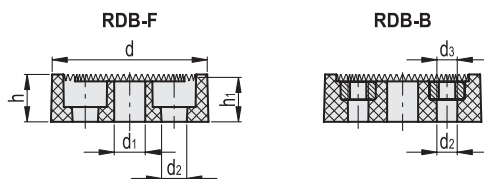
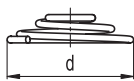

Application example

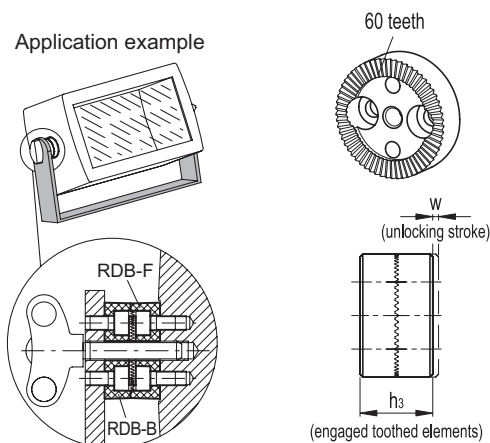

Code	Description	d	d1	d2	d3	d4	d5	d6	f	h	h1	h2	h3	s	w min.	C# [Nm]	⚖️
51981	RDB.32-60-F	32	6.3	5	-	5	23.5	-	18	9.5	9	-	18	-	1.2	80	9
51991	RDB.40-60-F	40	8.3	6	-	6	30	-	23	12	11.4	-	22.8	-	1.3	120	16
51983	RDB.32-60-B	32	6.3	4	M4	5	23.5	-	18	9.5	9	-	18	7	1.2	80	10
51993	RDB.40-60-B	40	8.3	5	M5	6	30	-	23	12	11.4	-	22.8	8	1.3	120	18
51985	RDB.32-60-CF	35.5	6.3	5	-	5	23.5	32.5	18	9.5	9	8.2	18	-	1.2	80	15
51995	RDB.40-60-CF	43.5	8.3	6	-	6	30	40	23	12	11.4	10.5	22.8	-	1.3	140	26
51987	RDB.32-60-CB	35.5	6.3	4	M4	5	23.5	32.5	18	9.5	9	8.2	18	7	1.2	80	16
51997	RDB.40-60-CB	43.5	8.3	5	M5	6	30	40	23	12	11.4	10.5	22.8	8	1.3	140	28

The maximum torque exercisable (C) is the torque applied to the two fully meshed toothed elements beyond which the material can give rise to some type of failure such as to compromise the functionality of the product. This value will obviously be affected by a coefficient that takes into account the importance and the security level of the specific application.