

## Folding handles with recessed tray

with return springs, technopolymer

### MATERIAL

Glass-fibre reinforced polyamide based (PA) technopolymer.

### STANDARD EXECUTIONS

Pass-through holes for M4 or M5 countersunk-head screws (not supplied).

- **MPR**: RAL 9005 black colour or RAL 7040 (C33) grey colour, matte finish.

- **MPR-CLEAN**: white colour similar to RAL 9002, matte finish.

### ROTATION PIN AND RETURN SPRINGS

AISI 303 stainless steel pin, AISI 302 stainless steel springs.

### TECHNICAL DATA

The lifting resistance (F1) and tensile strength (F2) values reported in the table are the result of permanent deformation by means of the appropriate dynamometric equipment under the test conditions shown in the figure with ambient temperature.

### ASSEMBLY INSTRUCTIONS

Drill the handle housing according to the template dimensions.



ELESA Original design

	x	y	f1	f2
MPR.141	135 <sup>+0.2</sup>	65 <sup>+0.2</sup>	118 <sup>+/-0.1</sup>	79 <sup>+/-0.1</sup>
MPR.167	158 <sup>-0.2</sup>	86 <sup>-0.2</sup>	141 <sup>+/-0.1</sup>	98 <sup>+/-0.1</sup>

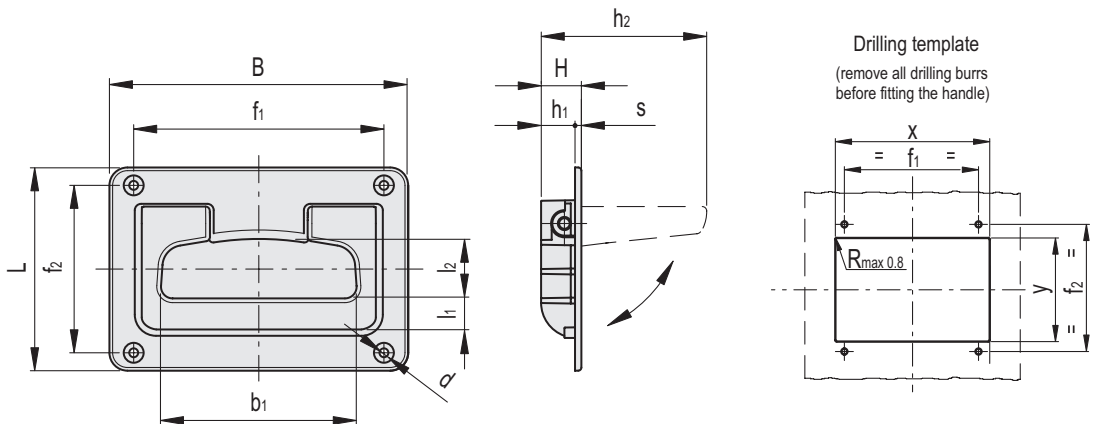
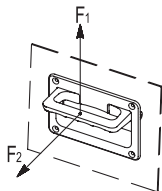

### MPR

Code	Description	B	f1	f2	L	H	h1	h2	b1	l1	l2	s	d	F1 [N]	F2 [N]	⚖️
43851	MPR.141	141	118	79	96	19	16	63	90	16.5	29	3	4.2	1650	2400	146
43851-C33	MPR.141-C33	141	118	79	96	19	16	63	90	16.5	29	3	4.2	1650	2400	146
43861	MPR.167	167	141	98	116	21	18	78	105	17	43	3	5.2	2000	2700	214
43961-C33	MPR.167-C33	167	141	98	116	21	18	78	105	17	43	3	5.2	2000	2700	214

### MPR-CLEAN

Code	Description	B	f1	f2	L	H	h1	h2	b1	l1	l2	s	d	F1 [N]	F2 [N]	⚖️
151061	MPR.141-CLEAN	141	118	79	96	19	16	63	90	16.5	29	3	4.2	1650	2400	146
151065	MPR.167-CLEAN	167	141	98	116	21	18	78	105	17	43	3	5.2	2000	2700	214