

## Adjustable feet

### technopolymer base, SUPER-technopolymer joint

#### BASE

Glass-fibre reinforced polyamide based (PA) technopolymer, black colour, matte finish.

#### BALL JOINT

Glass-fibre reinforced polyamide based (PA) SUPER-technopolymer, black colour.

#### STANDARD EXECUTIONS

- **LV.A+SJF**: without no-slip disk.
- **LV.A-AS+SJF**: with NBR rubber no-slip disk, hardness 70 Shore A, supplied assembled to the base.

#### FEATURES AND APPLICATIONS

The special knurling under the base edge that rests on the ground provides excellent grip and stability on uneven surfaces even without the no-slip disk.

The particular assembling system of the no-slip disk to the base assures a perfect anchoring, preventing separation even in case of impact during transport or of adhesion (sticking) to the floor (see No-slip disk).

Used for direct fixing using standard screws, without the need for a threaded stem.

#### ANOTHER STANDARD EXECUTION

SJF: ball joint.



ELESA Original design

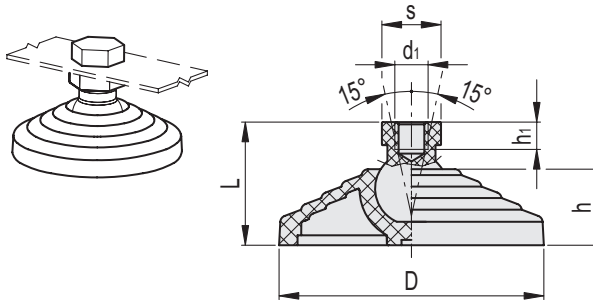

#### LV.A+SJF

Code	Description	D	d <sub>1</sub>	L	h	h <sub>1</sub>	s	Articulation ∅	Maximum tightening torque for the screw [Nm]	Max. limit static load* [N]	⚖
300101	LV.A-60-14+SJF-M6	60	M6	34.6	24	10	16	14	4	5800	38
300102	LV.A-60-14+SJF-M8	60	M8	34.6	24	10	16	14	6	6900	37
300106	LV.A-60-24+SJF-M10	60	M10	43.4	24	16	24	24	10	10500	48
300107	LV.A-60-24+SJF-M12	60	M12	43.4	24	16	24	24	12	10700	47
300111	LV.A-70-14+SJF-M6	70	M6	30.6	19	10	16	14	4	5600	36
300112	LV.A-70-14+SJF-M8	70	M8	30.6	19	10	16	14	6	6700	35
300116	LV.A-80-14+SJF-M6	80	M6	35.4	24	10	16	14	4	7400	59
300117	LV.A-80-14+SJF-M8	80	M8	35.4	24	10	16	14	6	8800	58
300121	LV.A-80-24+SJF-M10	80	M10	44	24	16	24	24	10	9600	68
300122	LV.A-80-24+SJF-M12	80	M12	44	24	16	24	24	12	9600	67
300126	LV.A-100-14+SJF-M6	100	M6	35	24	10	16	14	4	8100	88
300127	LV.A-100-14+SJF-M8	100	M8	35	24	10	16	14	6	9700	87
300131	LV.A-100-24+SJF-M10	100	M10	44	24	16	24	24	10	14000	100
300132	LV.A-100-24+SJF-M12	100	M12	44	24	16	24	24	12	14000	99
300136	LV.A-125-24+SJF-M10	125	M10	66.4	46	16	24	24	10	16900	209
300137	LV.A-125-24+SJF-M12	125	M12	66.4	46	16	24	24	12	16900	208

\* The max static load is the value above which the load applied to the element may cause some plastic material breakage, in particular conditions of use. Obviously, a factor that takes into consideration the importance and the safety level of the specific application must be applied to this value.



Levelling elements 11

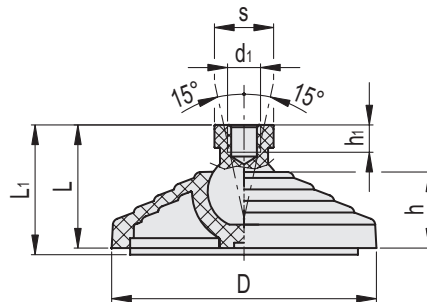

LV.A-AS+SJF

Code	Description	D	d <sub>1</sub>	L	L <sub>1</sub>	h	h <sub>1</sub>	s	Articulation ∅	Maximum tightening torque for the screw [Nm]	Max. limit static load* [N]	⚖
300201	LV.A-60-14-AS+SJF-M6	60	M6	34.6	37.6	24	10	16	14	4	5800	57
300202	LV.A-60-14-AS+SJF-M8	60	M8	34.6	37.6	24	10	16	14	6	6900	56
300206	LV.A-60-24-AS+SJF-M10	60	M10	43.4	46.4	24	16	24	24	10	10500	67
300207	LV.A-60-24-AS+SJF-M12	60	M12	43.4	46.4	24	16	24	24	12	10700	66
300211	LV.A-70-14-AS+SJF-M6	70	M6	30.6	33.6	19	10	16	14	4	5600	56
300212	LV.A-70-14-AS+SJF-M8	70	M8	30.6	33.6	19	10	16	14	6	6700	55
300216	LV.A-80-14-AS+SJF-M6	80	M6	35.4	38.4	24	10	16	14	4	7400	85
300217	LV.A-80-14-AS+SJF-M8	80	M8	35.4	38.4	24	10	16	14	6	8800	84
300221	LV.A-80-24-AS+SJF-M10	80	M10	44	47	24	16	24	24	10	9600	94
300222	LV.A-80-24-AS+SJF-M12	80	M12	44	47	24	16	24	24	12	9600	93
300226	LV.A-100-14-AS+SJF-M6	100	M6	35	38	24	10	16	14	4	8100	142
300227	LV.A-100-14-AS+SJF-M8	100	M8	35	38	24	10	16	14	6	9700	141
300231	LV.A-100-24-AS+SJF-M10	100	M10	44	47	24	16	24	24	10	14000	154
300232	LV.A-100-24-AS+SJF-M12	100	M12	44	47	24	16	24	24	12	14000	153
300236	LV.A-125-24-AS+SJF-M10	125	M10	66.4	69.4	46	16	24	24	10	16900	334
300237	LV.A-125-24-AS+SJF-M12	125	M12	66.4	69.4	46	16	24	24	12	16900	333

\* The max static load is the value above which the load applied to the element may cause some plastic material breakage, in particular conditions of use. Obviously, a factor that takes into consideration the importance and the safety level of the specific application must be applied to this value.