

Oil level indicators

Technopolymer

MATERIAL

Polyamide based (PA) technopolymer, black or red colour, glossy finish (HGFT/SL only black colour).

WINDOW

Transparent polyamide based (PA-T/AR) technopolymer.

PACKING RING

NBR synthetic rubber.

STANDARD EXECUTIONS

- **HGFT.**: with matte anodised aluminium star-shaped contrast screen with red central level point.
- **HGFT/SL.**: without contrast screen.

MAXIMUM CONTINUOUS WORKING TEMPERATURE

100°C at 3 bar pressure.

NOTE

For use with other fluids with special additives, please contact ELESA Sales Department.

ACCESSORIES ON REQUEST

Brass nut type GH. (see page 1743) for fitting to reservoirs with wall thickness smaller than 5 mm.



ELESA Original design

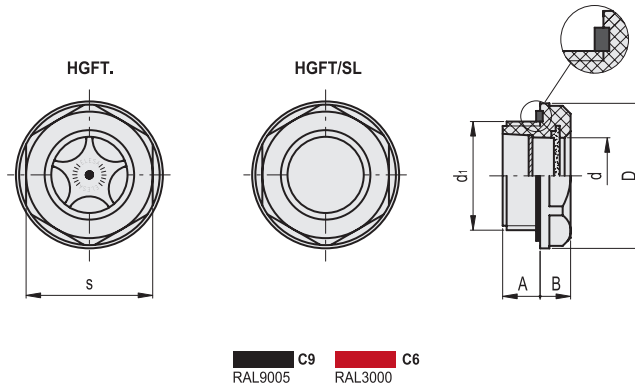

C9
 RAL9005
 C6
 RAL3000

HGFT.

Code	Description	Code	Description	d1	A	B	D	d	s	Tightening torque [Nm]	⚖️
14441	HGFT.10-3/8 C9	14444	HGFT.10-3/8 C6	G 3/8	8	7	24	11	22	4÷8	4
14461	HGFT.13-1/2 C9	14464	HGFT.13-1/2 C6	G 1/2	10	8.5	28	14.5	24	6÷8	6
14481	HGFT.16-3/4 C9	14484	HGFT.16-3/4 C6	G 3/4	9.5	8.5	35	18	32	8÷10	10
14521	HGFT.21-1 C9	14524	HGFT.21-1 C6	G 1	11	9.5	42.5	23	38	10÷12	15
14541	HGFT.25-1¼ C9	14544	HGFT.25-1¼ C6	G1 1/4	11	9	50	30	46	12÷15	30
14561	HGFT.40-2 C9	14564	HGFT.40-2 C6	G 2	12	11	68	40	62	12÷15	60

HGFT/SL

Code	Description	d1	A	B	D	d	s	Tightening torque [Nm]	⚖️
14446	HGFT.10/SL-3/8	G 3/8	8	7	24	11	22	4÷8	3
14466	HGFT.13/SL-1/2	G 1/2	10	8.5	28	14.5	24	6÷8	5
14486	HGFT.16/SL-3/4	G 3/4	9.5	8.5	35	18	32	8÷10	9
14526	HGFT.21/SL-1	G 1	11	9.5	42.5	23	38	10÷12	14
14546	HGFT.25/SL-1¼	G1 1/4	11	9	50	30	46	12÷15	29
14566	HGFT.40/SL-2	G 2	12	11	68	40	62	12÷15	59