

- 2 Type**
- SL** not lockable
 - SCL** lockable (same lock)
 - SUL** lockable (different lock)

1

l_1	b_1	b_2	b_3	d	h_1	h_2	l_2	l_3	l_4	l_5	l_6	m_1	m_2
72	10,3	21	15	6,5	33	24	104	45	40	14,5	12,5	56	23

Specification

- Housing
Zinc die casting
plastic coated
black, RAL 9005, textured finish ● **SW**
silver, RAL 9006, textured finish ○ **SR**
- Covers and latch
Plastic
- black-gray for SW
- light gray for SR
- Lock mechanism
Zinc die casting
- Key
Steel, nickel plated
- other parts
Steel zinc plated, blue passivated
- **RoHS compliant**

3

Information

GN 936 slam latches enable doors and closures to be effortlessly closed. The latch engages automatically when the door is closed preventing the door from opening unintentionally.

The slots enable the slam latch to be fitted to **profile systems** with different cross-sections.

The lockable versions of the slam latches (SCL and SUL types) are each supplied with 2 keys. The key can be removed in both end positions.

see also...

- *Assembly sets for profile systems 30 / 40 GN 965 → Page 1428*
- *Assembly sets for profile systems 30 / 40 / 45 GN 968 → Page 1438*

How to order

GN936-72-SCL-SW

1	l_1
2	Type
3	Color

Assembly instruction

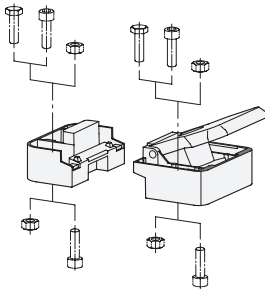
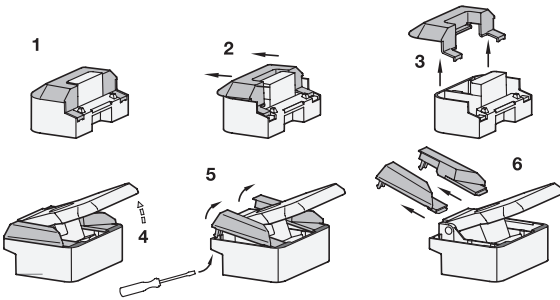

Prior to installation remove the slam latch cover as shown in the sketch. Socket head cap screws DIN 912, hexagon head screws DIN 933 and hexagon nuts ISO 4032 each with thread size M 6 can be used for mounting the slam latch.

After installation the covers are reassembled in reverse order. The covers cannot be removed when the slam latch is closed and consequently protect against vandalism.

The slots allow the slam latch to be fitted to the door frame or profile systems both from the operating side and from the rear. The installation clearance of 1 mm is also easy to adjust.

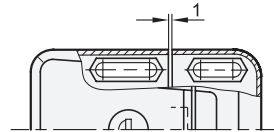

Example of application

