

GN 924-A

Spoked handwheels

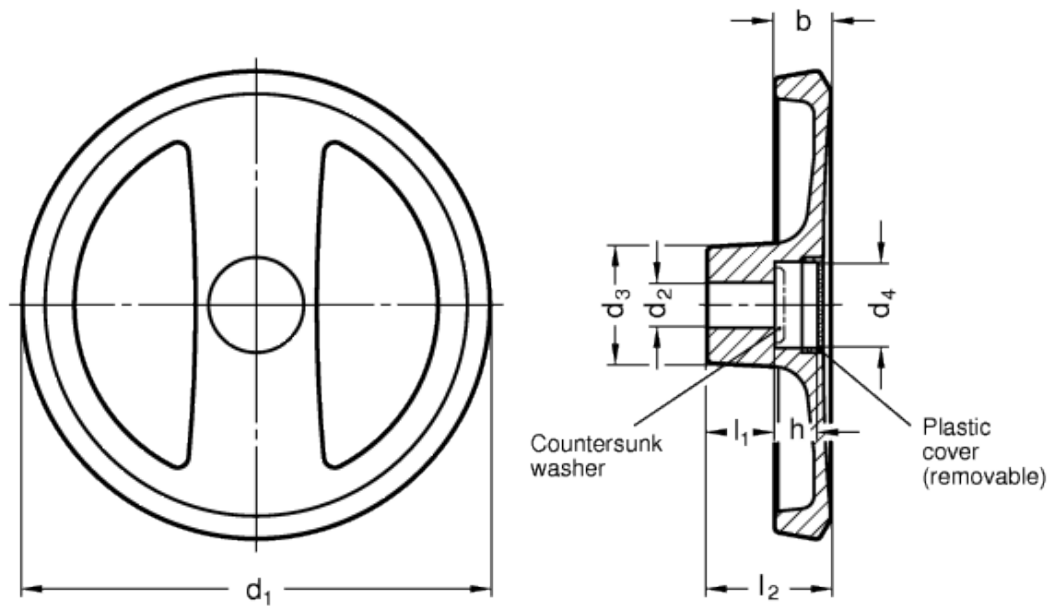

technical informations

Material

Aluminium pressure die casting, hub machined, rim turned.

Colour

- Version SW: plastic coated, black RAL 9005, textured finish.
- Version SR: plastic coated, silver RAL 9006, textured finish.

Assembly

- Version B: hub with H7 tolerance plain hole.

- Version K: hub with H7 reamed hole with keyway in compliance with [DIN 6885/1 P9 tolerance](#).
For fixing GN 924 on shafts by a grub screw see [Technical Data](#).

Plastic cover

Polyamide based (PA) technopolymer, light-grey colour, push-fit assembly

Features and applications

Spoked handwheels GN 924 are distinguished by modern design.
The removable plastic cover shrouds the fixing components such as screws, countersunk washers as well as the shaft end.

Accessories on request

Axial retaining washer [GN 184](#).

Technical data

Axial and radial runout lower than 0.4.

Standards Elements	Main dimensions						Bore		Recommended washer	Weight g
	Description	d ₁	l ₂ ≈	b	h	d ₃	d ₄	d _{2 H7}		
GN 924-125-B12-A-SW	125	33.5	15	11	31	23	12	18	GN 184-20	253
GN 924-125-B12-A-SR	125	33.5	15	11	31	23	12	18	GN 184-20	250
GN 924-125-K12-A-SW	125	33.5	15	11	31	23	12	18	GN 184-20	253
GN 924-125-K12-A-SR	125	33.5	15	11	31	23	14	18	GN 184-20	250
GN 924-125-B14-A-SW	125	33.5	15	11	31	23	14	18	GN 184-20	251
GN 924-125-B14-A-SR	125	33.5	15	11	31	23	14	18	GN 184-20	250
GN 924-125-K14-A-SW	125	33.5	15	11	31	23	14	18	GN 184-20	251
GN 924-125-K14-A-SR	125	33.5	15	11	31	23	14	18	GN 184-20	250
GN 924-140-B14-A-SW	140	36.5	16.5	13	36	28.5	14	19	GN 184-25	337
GN 924-140-B14-A-SR	140	36.5	16.5	13	36	28.5	14	19	GN 184-25	340
GN 924-140-K14-A-SW	140	36.5	16.5	13	36	28.5	14	19	GN 184-25	337
GN 924-140-K14-A-SR	140	36.5	16.5	13	36	28.5	14	19	GN 184-25	340
GN 924-140-B16-A-SW	140	36.5	16.5	13	36	28.5	16	19	GN 184-25	338
GN 924-140-B16-A-SR	140	36.5	16.5	13	36	28.5	16	19	GN 184-25	460
GN 924-140-K16-A-SW	140	36.5	16.5	13	36	28.5	16	19	GN 184-25	338
GN 924-140-K16-A-SR	140	36.5	16.5	13	36	28.5	16	19	GN 184-25	440
GN 924-160-B14-A-SW	160	39.5	18	14.5	36	28.5	14	20	GN 184-25	460
GN 924-160-B14-A-SR	160	39.5	18	14.5	36	28.5	14	20	GN 184-25	560
GN 924-160-K14-A-SW	160	39.5	18	14.5	36	28.5	14	20	GN 184-25	460
GN 924-160-K14-A-SR	160	39.5	18	14.5	36	28.5	14	20	GN 184-25	560
GN 924-160-B16-A-SW	160	39.5	18	14.5	36	28.5	16	20	GN 184-25	460
GN 924-160-B16-A-SR	160	39.5	18	14.5	36	28.5	16	20	GN 184-25	500
GN 924-160-K16-A-SW	160	39.5	18	14.5	36	28.5	16	20	GN 184-25	460
GN 924-160-K16-A-SR	160	39.5	18	14.5	36	28.5	16	20	GN 184-25	500
GN 924-200-B18-A-SW	200	45.5	20.5	16	42	36	18	24	GN 184-32	720
GN 924-200-B18-A-SR	200	45.5	20.5	16	42	36	18	24	GN 184-32	730
GN 924-200-K18-A-SW	200	45.5	20.5	16	42	36	18	24	GN 184-32	720
GN 924-200-K18-A-SR	200	45.5	20.5	16	42	36	18	24	GN 184-32	730
GN 924-200-B20-A-SW	200	45.5	20.5	16	42	36	20	24	GN 184-32	740
GN 924-200-B20-A-SR	200	45.5	20.5	16	42	36	20	24	GN 184-32	740
GN 924-200-K20-A-SW	200	45.5	20.5	16	42	36	20	24	GN 184-32	740
GN 924-200-K20-A-SR	200	45.5	20.5	16	42	36	20	24	GN 184-32	740

This product had the following design awards:



