

GN 923.7

Solid handwheels with safety fold-away handle

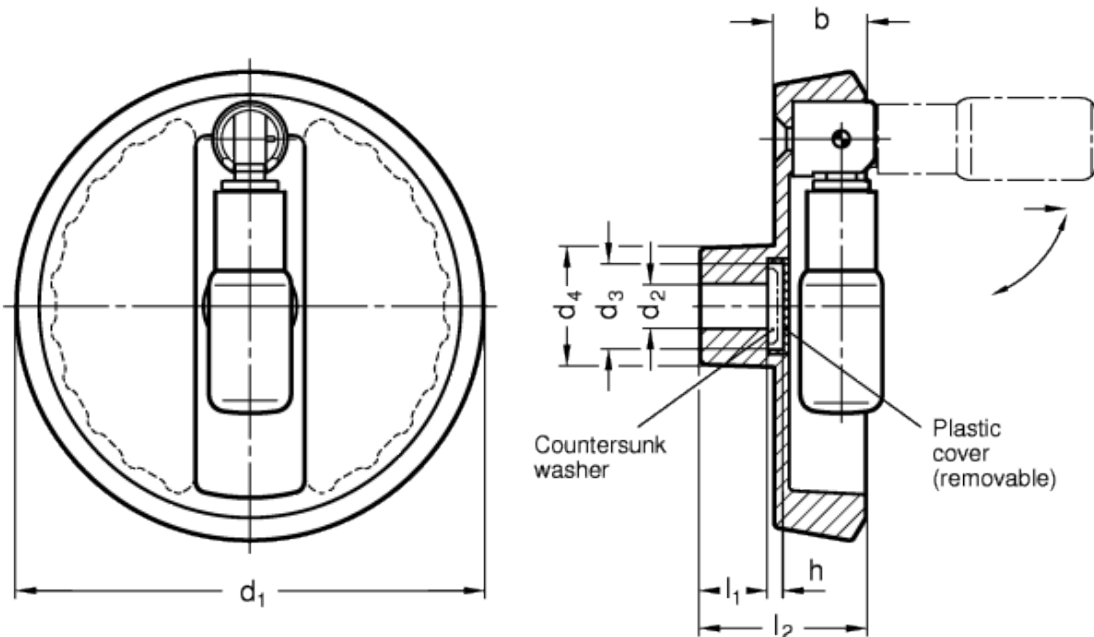

technical informations

Material

Aluminium pressure die casting, hub machined, rim turned.

Colour

- Version SW: plastic coated, black RAL 9005, textured finish.
- Version SR: plastic coated, silver RAL 9006, textured finish.

Assembly

- Version B: hub with H7 tolerance plain hole.
 - Version K: hub with H7 reamed hole with keyway in compliance with [DIN 6885/1 P9 tolerance](#).
 For fixing GN 923.7 on shafts by a grub screw see [Technical Data](#).

Plastic cover

Polyamide based (PA) technopolymer, light-grey colour, push-fit assembly

Fold-away handle

Type GN 798.7 in polyamide based (PA) technopolymer, black colour, matte finish. Resistant to solvents, oils, greases and other chemical agents. The two-volume special design of the handle provides the operator's hand with a safe and ergonomic grip when turning the handwheel.

Features and applications

Solid handwheels GN 923.7 with safety fold-away handle are distinguished by modern design. These handwheels are suitable for applications where the handle must not remain in the operation position. In order to bring the handle into this position it has to be turned first through 90° to a stop against a torsion spring and then it is pushed against spring pressure into its hold position. By maintaining the forward thrust on the handle the handwheel can easily be rotated. When releasing the handle the springs returns it back to the retracted position.

Accessories on request

Axial retaining washer [GN 184](#).

Technical data

Axial and radial runout lower than 0.4.

Standard Elements	Main dimensions						Bore		Handle	Recommended washer	Weight
Description	d ₁	l ₂	b	h	d ₃	d ₄	d _{2H7}	l ₁	Ø		g
GN 923.7-125-B12-R-*	125	45	24.5	4	23	31	12	18	22	GN 184-22	450
GN 923.7-125-K12-R-*	125	45	24.5	4	23	31	12	18	22	GN-184-22	435
GN 923.7-125-B14-R-*	125	45	24.5	4	23	31	14	18	22	GN 184-22	500
GN 923.7-125-K14-R-*	125	45	24.5	4	23	31	14	18	22	GN-184-22	500
GN 923.7-140-B14-R-*	140	47	26	4	23	36	14	19	24	GN 184-22	590
GN 923.7-140-K14-R-*	140	47	26	4	23	36	14	19	24	GN-184-22	590
GN 923.7-140-B16-R-*	140	47	26	4	23	36	16	19	24	GN-184-22	600
GN 923.7-140-K16-R-*	140	47	26	4	23	36	16	19	24	GN-184-22	600
GN 923.7-160-B14-R-*	160	48	26	4	23	36	14	20	24	GN 184-22	750
GN 923.7-160-K14-R-*	160	48	26	4	23	36	14	20	24	GN-184-22	750
GN 923.7-160-B16-R-*	160	48	26	4	23	36	16	20	24	GN 184-22	900
GN 923.7-160-K16-R-*	160	48	26	4	23	36	16	20	24	GN-184-22	900
GN 923.7-200-B18-R-*	200	53	27	4	23	42	18	24	25	GN 184-22	1000
GN 923.7-200-K18-R-*	200	53	27	4	23	42	18	24	25	GN-184-22	1000
GN 923.7-200-B20-R-*	200	53	27	4	23	42	20	24	25	GN 184-22	1060
GN 923.7-200-K20-R-*	200	53	27	4	23	42	20	24	25	GN-184-22	1060

* Complete the description of the standard item needed by adding the colour of the handwheel: SW (black) or SR (silver).

This product had the following design awards:



reddot design award
winner 2010



STANDARD MACHINE ELEMENTS WORLDWIDE