

GN 923.3

Solid handwheels with fold-away handle

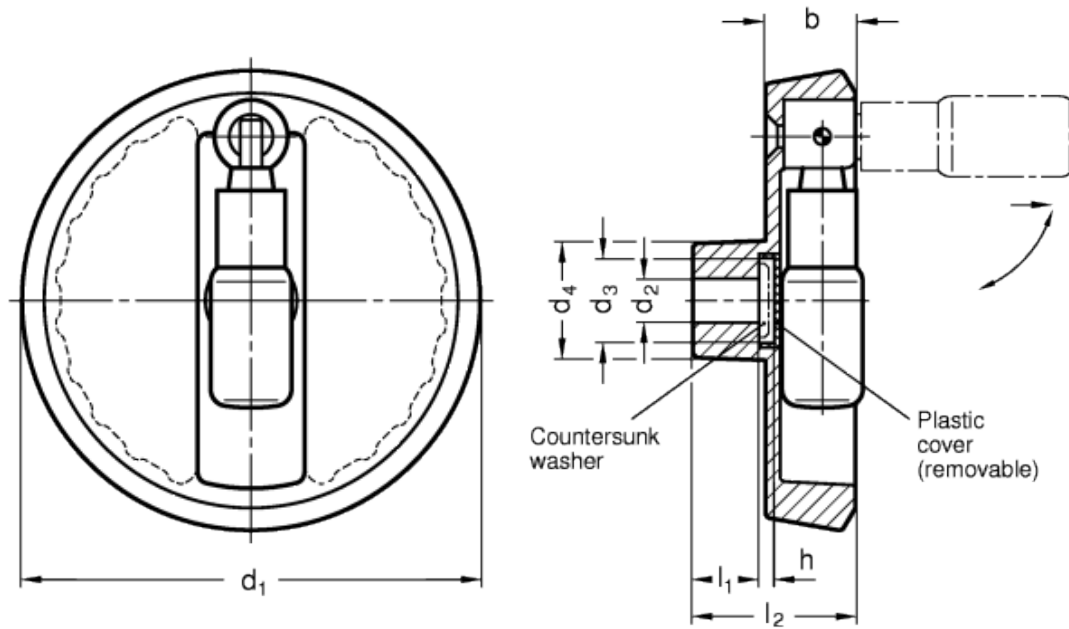

technical informations

Material

Aluminium pressure die casting, hub machined, rim turned.

Colour

- Version SW: plastic coated, black RAL 9005, textured finish.
- Version SR: plastic coated, silver RAL 9006, textured finish.

Assembly

- Version B: hub with H7 tolerance plain hole.
- Version K: hub with H7 reamed hole with keyway in compliance with [DIN 6885/1 P9 tolerance](#).

For fixing GN 923.3 on shafts by a grub screw see [Technical Data](#).

Plastic cover

Polyamide based (PA) technopolymer, light-grey colour, push-fit assembly.

Fold-away handle

Type GN 798.3 in polyamide based (PA) technopolymer, black colour, matte finish. Resistant to solvents, oils, greases and other chemical agents. The two-volume special design of the handle provides the operator's hand with a safe and ergonomic grip when turning the handwheel.

Accessories on request

Axial retaining washer [GN 184](#).

Features and applications

Solid handwheels GN 923.3 with fold away-handle are distinguished by modern design. The handle in these handwheels is locked in a conical bore in the operating position. For reversal, it must first be pulled from the cone in axial direction. A pressure spring holds the handle in both positions. When swung out, it automatically engages again.

Technical data

Axial and radial runout lower than 0.4.

Standard Elements	Main dimensions						Bore		Handle	Recommended washer	Weight
Description	d ₁	l ₂ ≈	b	h	d ₃	d ₄	d _{2 H7}	l ₁	Ø		g
GN 923.3-100-B10-R-*	100	39	20	4	18	28	10	17	18	GN 184-16	280
GN 923.3-100-K10-R-*	100	39	20	4	18	28	10	17	18	GN-184-16	275
GN 923.3-100-B12-R-*	100	39	20	4	18	28	12	17	18	GN 184-16	260
GN 923.3-100-K12-R-*	100	39	20	4	18	28	12	17	18	GN-184-16	255
GN 923.3-125-B12-R-*	125	45	24.5	4	23	31	12	18	22	GN 184-22	450
GN 923.3-125-K12-R-*	125	45	24.5	4	23	31	12	18	22	GN-184-22	440
GN 923.3-125-B14-R-*	125	45	24.5	4	23	31	14	18	22	GN 184-22	440
GN 923.3-125-K14-R-*	125	45	24.5	4	23	31	14	18	22	GN-184-22	430
GN 923.3-140-B14-R-*	140	47	26	4	23	36	14	19	24	GN 184-22	590
GN 923.3-140-K14-R-*	140	47	26	4	23	36	14	19	24	GN-184-22	585
GN 923.3-140-B16-R-*	140	47	26	4	23	36	16	19	24	GN 184-22	590
GN 923.3-140-K16-R-*	140	47	26	4	23	36	16	19	24	GN-184-22	585
GN 923.3-160-B14-R-*	160	48	26	4	23	36	14	20	24	GN 184-22	760
GN 923.3-160-K14-R-*	160	48	26	4	23	36	14	20	24	GN-184-22	750
GN 923.3-160-B16-R-*	160	48	26	4	23	36	16	20	24	GN 184-22	760
GN 923.3-160-K16-R-*	160	48	26	4	23	36	16	20	24	GN-184-22	750
GN 923.3-200-B18-R-*	200	53	27	4	23	42	18	24	25	GN 184-22	1100
GN 923.3-200-K18-R-*	200	53	27	4	23	42	18	24	25	GN-184-22	1090
GN 923.3-200-B20-R-*	200	53	27	4	23	42	20	24	25	GN 184-22	1100
GN 923.3-200-K20-R-*	200	53	27	4	23	42	20	24	25	GN-184-22	1090

* Complete the description of the standard item needed by adding the colour of the handwheel: SW (black) or SR (silver).

This product had the following design awards:



reddot design award
winner 2010



STANDARD MACHINE ELEMENTS WORLDWIDE