

GN 918.5

Cam locking levers

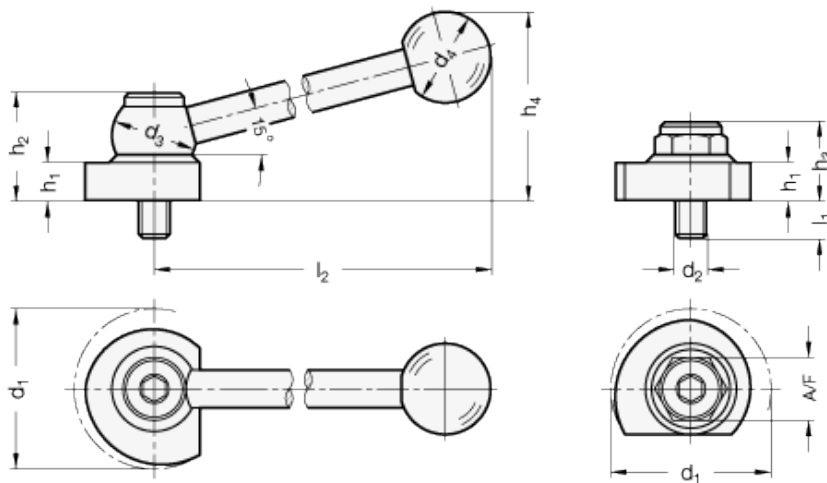

INOX
Stainless Steel



technical informations

Lever

AISI 303 stainless steel, shot-blasted matte finish.

Ball knob (type KV and GV)

DIN 319 Plastic, Duroplast, black shiny finish.

Screw

AISI 420 stainless steel, hexagon socket head.

Cam and washer

AISI 303 tempered stainless steel chemically nickel-plated.

Assembly

- Type KV: with ball lever, angular (serrations).
- Type GV: with ball lever, straight (serrations).
- Type SK: with hexagon.

Standard versions available

- Version R: clockwise rotation (drawn version).
- Version L: anti-clockwise rotation.

Features and applications

Eccentric cams GN 918.5 allow rapid and safe clamping and releasing with a relatively long movement and high clamping force. The small rising angle of the helix makes it self arresting.

The ball handle is linked with the clamping mechanism via a serrated ratchet thus allowing an „individual positioning“ of the hand lever.

Screw bolt and washer are matched to allow an effortless release from the clamped position. The washer „saves“ special requirements to the execution of the female thread and the clamping bolt can therefore also be used on T-Nuts on machine beds.

Drawn version: Type KV, Clamping direction R clockwise rotation

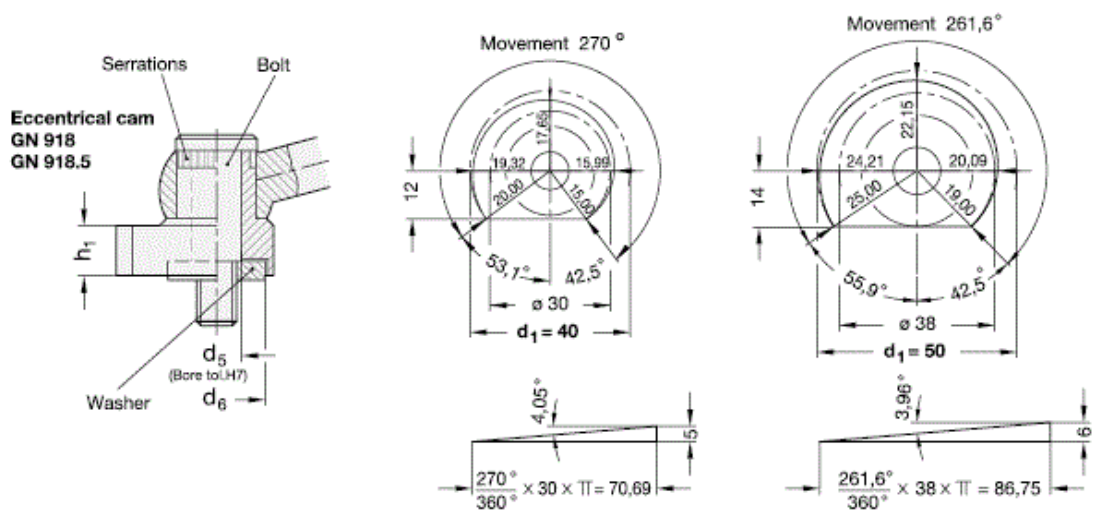

$d_1 -0,5$	d_5	d_6	h_1
40	10	20	10
50	12	24	12

Standard Elements	Main dimensions												Threaded stud		Weight
	Description	$d_{1-0.5}$	d_3	d_4	d_5	d_6	h_1	h_2	h_3	$h_{4 \approx}$	h_5	$l_{2 \approx}$	A/F	d_2	
GN 918.5-40-KV-R	40	24	25	10	20	10	31	-	55	-	100	-	M8	8	180
GN 918.5-40-KV-L	40	24	25	10	20	10	31	-	55	-	100	-	M8	8	180
GN 918.5-40-GV-R	40	24	25	10	20	10	31	-	-	31	100	-	M8	8	170
GN 918.5-40-GV-L	40	24	25	10	20	10	31	-	-	31	100	-	M8	8	170
GN 918.5-40-SK-R	40	-	-	10	20	10	-	21	-	-	-	15	M8	8	100
GN 918.5-40-SK-L	40	-	-	10	20	10	-	21	-	-	-	15	M8	8	100
GN 918.5-50-KV-R	50	28	30	12	24	12	34.5	-	62	-	116	-	M10	11	310
GN 918.5-50-KV-L	50	28	30	12	24	12	34.5	-	62	-	116	-	M10	11	310
GN 918.5-50-GV-R	50	28	30	12	24	10	34.5	-	-	36	116	-	M10	11	300
GN 918.5-50-GV-L	50	28	30	12	24	12	34.5	-	-	36	116	-	M10	11	300
GN 918.5-50-SK-R	50	-	-	12	24	12	-	24	-	-	-	19	M10	11	154
GN 918.5-50-SK-L	50	-	-	12	24	12	-	24	-	-	-	19	M10	11	154



STANDARD MACHINE ELEMENTS WORLDWIDE