

Adjustable Hand Levers for Tube Clamp Connectors / Linear Actuator Connectors

SPECIFICATION

Handle
Zinc die casting
Powder coated
Silver, RAL 9006, textured finish **SR**
Threaded insert and retaining screw
Stainless steel AISI 303

INFORMATION

Adjustable hand levers GN 911 replace the socket cap screws DIN 912 of the tube clamp connectors and linear actuator connectors.

The table of dimensions of the tube clamp connectors and linear actuator connectors shows the matching hand lever for each screw location.

TECHNICAL INFORMATION

- Stainless Steel characteristics (see page A26)

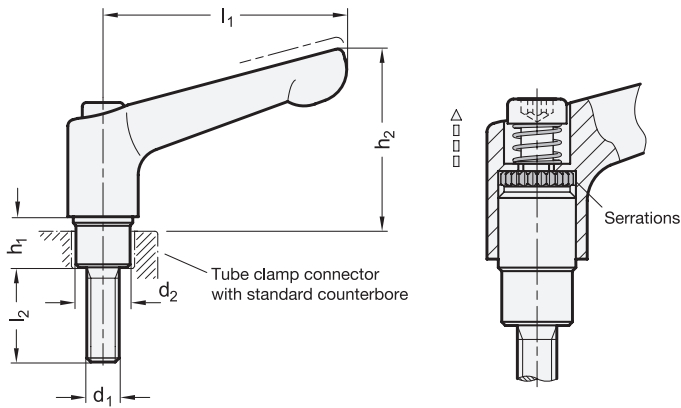

GN 911

Description	l1	d1	l2	d2	h1	h2 ≈	⚖
GN 911-45-M6-20-SR	45	M 6	20	10	9	34	41
GN 911-63-M6-20-SR	63	M 6	20	10	12	44	84
GN 911-63-M8-25-SR	63	M 8	25	13	12.5	42	92
GN 911-63-M8-30-SR	63	M 8	30	13	12.5	42	94
GN 911-63-M8-35-SR	63	M 8	35	13	12.5	42	96
GN 911-63-M8-50-SR	63	M 8	50	13	12.5	42	102
GN 911-78-M8-25-SR	78	M 8	25	13	15	52	148
GN 911-78-M8-30-SR	78	M 8	30	13	15	52	150
GN 911-78-M8-35-SR	78	M 8	35	13	15	52	152
GN 911-78-M8-50-SR	78	M 8	50	13	15	52	163
GN 911-78-M10-35-SR	78	M 10	35	16	16	50	166
GN 911-78-M10-50-SR	78	M 10	50	16	16	50	176
GN 911-78-M10-55-SR	78	M 10	55	16	16	50	179
GN 911-78-M10-60-SR	78	M 10	60	16	16	50	182
GN 911-92-M10-35-SR	92	M 10	35	16	16	60	220
GN 911-92-M10-50-SR	92	M 10	50	16	16	60	229
GN 911-92-M10-55-SR	92	M 10	55	16	16	60	232
GN 911-92-M10-60-SR	92	M 10	60	16	16	60	235