

Adjustable slide units

SPECIFICATION

Types

- Type **D**: with Control knob
- Type **H**: with handwheel (from size 50 upwards)
- Type **DN**: with control knob and digital position indicator DD51 (from size 50 upwards) (see page 718)
- Type **DR**: with control knob and digital position indicator DD51 (from size 50 upwards) (see page 718)
- Type **HN**: with handwheel and digital position indicator DD51 (from size 50 upwards) (see page 718)
- Type **HR**: with handwheel and digital position indicator DD51 (from size 50 upwards) (see page 718)
- Type **S**: without adjustable spindle and operating element (i. e. for mounting a pneumatic cylinder)

Identification No.

- No. **1**: without adjustable hand lever
- No. **2**: with adjustable hand lever (only from b=50)

Slides / end plates
Aluminium press formed
anodized extrusion, natural colour

Guide shafts
Stainless Steel

Drive

- Lead spindle / ball bearing Stainless Steel
- Lead nut Plastic

Fixing screws
Stainless Steel

Control knob / Scale ring
Aluminium, black anodized

INFORMATION

Adjustable slide units GN 900 can be combined with a range of adaptors to give various axis configurations.

These fastening units and connecting sets (GN 900.1, GN 900.2, GN 900.3) can be clamped to the adjustable slide units in a rapid and simple way.

For fine adjustment there is a scale ring graduated in increments of 0.05 mm, with digital position indicator 0.02 mm.

Furthermore this adjustable slide units (Type D, with control knob) is rust proof.

* Complete with identification no. of the adjustable slide unit (1 or 2)

- | | |
|-------------------------------|----------------------------|
| 1 | 2 |
| without adjustable hand lever | with adjustable hand lever |

GN 900



TECHNICAL INFORMATION

- Disc handwheels VDN.FP (see page 162)

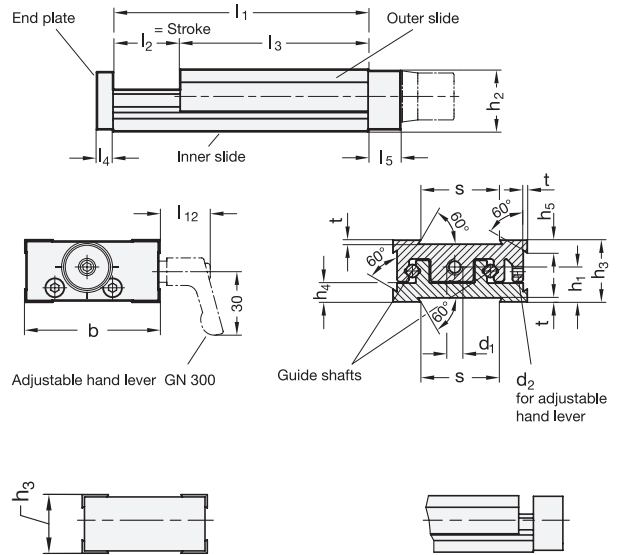

GN 900-S

Description	b	l1 - l2	d1	d2	h1	h2	h3	h5	l3	l4	l5	l12	s	t	⚖
GN 900-50-95-25-S-*	50	95-25	M6 x1	M4	13	22.5	23	4.5	70	6	12	36	30	1.5	252
GN 900-50-120-50-S-*	50	120-50	M6 x1	M4	13	22.5	23	4.5	70	6	12	36	30	1.5	276
GN 900-50-145-75-S-*	50	145-75	M6 x1	M4	13	22.5	23	4.5	70	6	12	36	30	1.5	306
GN 900-50-170-100-S-*	50	170-100	M6 x1	M4	13	22.5	23	4.5	70	6	12	36	30	1.5	340
GN 900-80-145-25-S-*	80	145-25	M8 x1	M5	20.5	35.5	36	10	120	8	16	25	50	2	950
GN 900-80-170-50-S-*	80	170-50	M8 x1	M5	20.5	35.5	36	10	120	8	16	25	50	2	1000
GN 900-80-195-75-S-*	80	195-75	M8 x1	M5	20.5	35.5	36	10	120	8	16	25	50	2	1080
GN 900-80-220-100-S-*	80	220-100	M8 x1	M5	20.5	35.5	36	10	120	8	16	25	50	2	1250
GN 900-120-185-25-S-*	120	185-25	M10 x1	M5	26.3	45	46	10	160	10	18	25	80	2	2500
GN 900-120-210-50-S-*	120	210-50	M10 x1	M5	26.3	45	46	10	160	10	18	25	80	2	2785
GN 900-120-235-75-S-*	120	235-75	M10 x1	M5	26.3	45	46	10	160	10	18	25	80	2	2952
GN 900-120-260-100-S-*	120	260-100	M10 x1	M5	26.3	45	46	10	160	10	18	25	80	2	3457

Weight identification no. 1

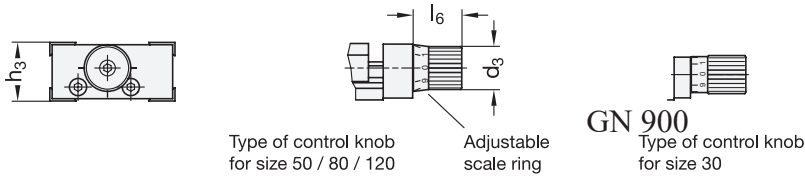

GN 900-D

Description	b	l1 - l2	d1	d2	d3	h1	h2	h3	h4	h5	l3	l4	l5	l6	l12	s	t	⚖
GN 900-30-50-5-D-1	30	50-5	M4 x 0.5	M3	14	9.3	16	17	4	3	45	4	6	20	-	16	1	80
GN 900-30-55-10-D-1	30	55-10	M4 x 0.5	M3	14	9.3	16	17	4	3	45	4	6	20	-	16	1	80
GN 900-30-60-15-D-1	30	60-15	M4 x 0.5	M3	14	9.3	16	17	4	3	45	4	6	20	-	16	1	85
GN 900-30-65-20-D-1	30	65-20	M4 x 0.5	M3	14	9.3	16	17	4	3	45	4	6	20	-	16	1	97
GN 900-50-95-25-D-1	50	95-25	M6 x 1	M4	14	13	22.5	23	7	4.5	70	6	12	20	-	30	1.5	300
GN 900-50-120-50-D-1	50	120-50	M6 x 1	M4	17	13	22.5	23	7	4.5	70	6	12	20	-	30	1.5	340
GN 900-50-145-75-D-1	50	145-75	M6 x 1	M4	17	13	22.5	23	7	4.5	70	6	12	20	-	30	1.5	366
GN 900-50-170-100-D-1	50	170-100	M6 x 1	M4	17	13	22.5	23	7	4.5	70	6	12	20	-	30	1.5	400
GN 900-80-145-25-D-1	80	145-25	M8 x 1	M5	22	20.5	35.5	36	10	10	120	8	16	24	-	50	2	1060
GN 900-80-170-50-D-1	80	170-50	M8 x 1	M5	22	20.5	35.5	36	10	10	120	8	16	24	-	50	2	1100
GN 900-80-195-75-D-1	80	195-75	M8 x 1	M5	22	20.5	35.5	36	10	10	120	8	16	24	-	50	2	1220
GN 900-80-220-100-D-1	80	220-100	M8 x 1	M5	22	20.5	35.5	36	10	10	120	8	16	24	-	50	2	1300
GN 900-120-185-25-D-1	120	185-25	M10 x 1	M5	34	26.3	45	46	13.8	10	160	10	18	34	-	80	2	2800
GN 900-120-210-50-D-1	120	210-50	M10 x 1	M5	34	26.3	45	46	13.8	10	160	10	18	34	-	80	2	2950
GN 900-120-235-75-D-1	120	235-75	M10 x 1	M5	34	26.3	45	46	13.8	10	160	10	18	34	-	80	2	3118
GN 900-120-260-100-D-1	120	260-100	M10 x 1	M5	34	26.3	45	46	13.8	10	160	10	18	34	-	80	2	3318
GN 900-50-95-25-D-2	50	95-25	M6 x 1	M4	17	13	22.5	23	7	4.5	70	6	12	20	36	30	1.5	220
GN 900-50-120-50-D-2	50	120-50	M6 x 1	M4	17	13	22.5	23	7	4.5	70	6	12	20	36	30	1.5	360
GN 900-50-145-75-D-2	50	145-75	M6 x 1	M4	17	13	22.5	23	7	4.5	70	6	12	20	36	30	1.5	400
GN 900-50-170-100-D-2	50	170-100	M6 x 1	M4	17	13	22.5	23	7	4.5	70	6	12	20	36	30	1.5	430
GN 900-80-145-25-D-2	80	145-25	M8 x 1	M5	17	20.5	35.5	36	10	10	120	8	16	24	25	50	2	1080
GN 900-80-170-50-D-2	80	170-50	M8 x 1	M5	22	20.5	35.5	36	10	10	120	8	16	24	25	50	2	1160
GN 900-80-195-75-D-2	80	195-75	M8 x 1	M5	22	20.5	35.5	36	10	10	120	8	16	24	25	50	2	1250
GN 900-80-220-100-D-2	80	220-100	M8 x 1	M5	34	20.5	35.5	36	10	10	120	8	16	24	25	50	2	1300
GN 900-120-185-25-D-2	120	185-25	M10 x 1	M5	34	26.3	45	46	13.8	10	160	10	18	34	25	80	2	2800
GN 900-120-210-50-D-2	120	210-50	M10 x 1	M5	34	26.3	45	46	13.8	10	160	10	18	34	25	80	2	2900
GN 900-120-235-75-D-2	120	235-75	M10 x 1	M5	34	26.3	45	46	13.8	10	160	10	18	34	25	80	2	3000
GN 900-120-260-100-D-2	120	260-100	M10 x 1	M5	34	26.3	45	46	13.8	10	160	10	18	34	25	80	2	3320

* Complete with identification no. of the adjustable slide unit (1 or 2)

- 1 without adjustable hand lever
- 2 with adjustable hand lever

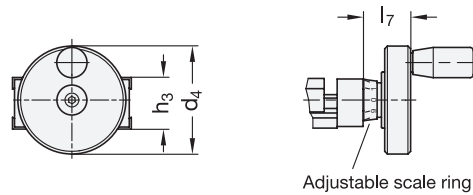

GN 900-H

Description	b	l1 - l2	d1	d2	d4	h1	h2	h3	h4	h5	l3	l4	l5	l7	l12	s	t	⚖
GN 900-50-95-25-H-*	50	95-25	M6 x 1	M4	50	13	22.5	23	7	4.5	70	6	12	22	36	30	1.5	355
GN 900-50-120-50-H-*	50	120-50	M6 x 1	M4	50	13	22.5	23	7	4.5	70	6	12	22	36	30	1.5	380
GN 900-50-145-75-H-*	50	145-75	M6 x 1	M4	50	13	22.5	23	7	4.5	70	6	12	22	36	30	1.5	421
GN 900-50-170-100-H-*	50	170-100	M6 x 1	M4	50	13	22.5	23	7	4.5	70	6	12	22	36	30	1.5	500
GN 900-80-145-25-H-*	80	145-25	M8 x 1	M5	80	20.5	35.5	36	10	10	120	8	16	31	25	50	2	1200
GN 900-80-170-50-H-*	80	170-50	M8 x 1	M5	80	20.5	35.5	36	10	10	120	8	16	31	25	50	2	1260
GN 900-80-195-75-H-*	80	195-75	M8 x 1	M5	80	20.5	35.5	36	10	10	120	8	16	31	25	50	2	1380
GN 900-80-220-100-H-*	80	220-100	M8 x 1	M5	80	20.5	35.5	36	10	10	120	8	16	31	25	50	2	1500
GN 900-120-185-25-H-*	120	185-25	M10 x 1	M5	100	26.3	45	46	13.8	10	160	10	18	40	25	80	2	3100
GN 900-120-210-50-H-*	120	210-50	M10 x 1	M5	100	26.3	45	46	13.8	10	160	10	18	40	25	80	2	3180
GN 900-120-235-75-H-*	120	235-75	M10 x 1	M5	100	26.3	45	46	13.8	10	160	10	18	40	25	80	2	3400
GN 900-120-260-100-H-*	120	260-100	M10 x 1	M5	100	26.3	45	46	13.8	10	160	10	18	40	25	80	2	3480

Weight identification no. 1



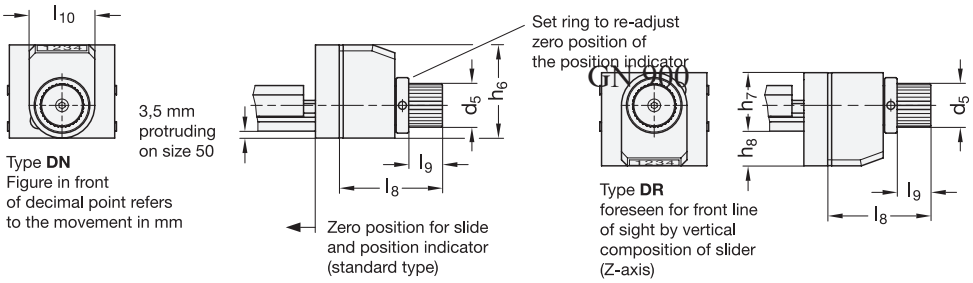

GN 900-DN/DR

Description	b	l1 - l2	d1	d2	d5	h1	h2	h3	h4	h5	h6	h7	h8	l3	l4	l5	l8	l9	l10	l12	s	t	△
GN 900-50-95-25-DN-1	50	95-25	M6 x 1	M4	22	13	22.5	23	7	4.5	47	-	-	70	6	12	52	24	33	-	30	1.5	370
GN 900-50-120-50-DN-1	50	120-50	M6 x 1	M4	22	13	22.5	23	7	4.5	47	-	-	70	6	12	52	24	33	-	30	1.5	450
GN 900-50-145-75-DN-1	50	145-75	M6 x 1	M4	22	13	22.5	23	7	4.5	47	-	-	70	6	12	52	24	33	-	30	1.5	500
GN 900-50-170-100-DN-1	50	170-100	M6 x 1	M4	22	13	22.5	23	7	4.5	47	-	-	70	6	12	52	24	33	-	30	1.5	520
GN 900-80-145-25-DN-1	80	145-25	M8 x 1	M5	22	20.5	35.5	36	10	10	51	-	-	120	8	16	55	27	33	-	50	2	1200
GN 900-80-170-50-DN-1	80	170-50	M8 x 1	M5	22	20.5	35.5	36	10	10	51	-	-	120	8	16	55	27	33	-	50	2	1250
GN 900-80-195-75-DN-1	80	195-75	M8 x 1	M5	22	20.5	35.5	36	10	10	51	-	-	120	8	16	55	27	33	-	50	2	1340
GN 900-80-220-100-DN-1	80	220-100	M8 x 1	M5	22	20.5	35.5	36	10	10	51	-	-	120	8	16	55	27	33	-	50	2	1400
GN 900-120-185-25-DN-1	120	185-25	M10 x 1	M5	34	26.3	45	46	13.8	10	57	-	-	160	10	18	69	41	33	-	80	2	3500
GN 900-120-210-50-DN-1	120	210-50	M10 x 1	M5	34	26.3	45	46	13.8	10	57	-	-	160	10	18	69	41	33	-	80	2	3400
GN 900-120-235-75-DN-1	120	235-75	M10 x 1	M5	34	26.3	45	46	13.8	10	57	-	-	160	10	18	69	41	33	-	80	2	3400
GN 900-120-260-100-DN-1	120	260-100	M10 x 1	M5	34	26.3	45	46	13.8	10	57	-	-	160	10	18	69	41	33	-	80	2	3400
GN 900-50-95-25-DR-1	50	95-25	M6 x 1	M4	22	13	22.5	23	7	4.5	-	29	18	70	6	12	52	24	33	-	30	1.5	420
GN 900-50-120-50-DR-1	50	120-50	M6 x 1	M4	22	13	22.5	23	7	4.5	-	29	18	70	6	12	52	24	33	-	30	1.5	700
GN 900-50-145-75-DR-1	50	145-75	M6 x 1	M4	22	13	22.5	23	7	4.5	-	29	18	70	6	12	52	24	33	-	30	1.5	800
GN 900-50-170-100-DR-1	50	170-100	M6 x 1	M4	22	13	22.5	23	7	4.5	-	29	18	70	6	12	52	24	33	-	30	1.5	900
GN 900-80-145-25-DR-1	80	145-25	M8 x 1	M5	22	20.5	35.5	36	10	10	-	37	10	120	8	16	55	27	33	-	50	2	1180
GN 900-80-170-50-DR-1	80	170-50	M8 x 1	M5	22	20.5	35.5	36	10	10	-	37	10	120	8	16	55	27	33	-	50	2	1263
GN 900-80-195-75-DR-1	80	195-75	M8 x 1	M5	22	20.5	35.5	36	10	10	-	37	10	120	8	16	55	27	33	-	50	2	1330
GN 900-80-220-100-DR-1	80	220-100	M8 x 1	M5	22	20.5	35.5	36	10	10	-	37	10	120	8	16	55	27	33	-	50	2	1415
GN 900-120-185-25-DR-1	120	185-25	M10 x 1	M5	34	26.3	45	46	13.8	10	-	45	5	160	10	18	69	41	33	-	80	2	2900
GN 900-120-210-50-DR-1	120	210-50	M10 x 1	M5	34	26.3	45	46	13.8	10	-	45	5	160	10	18	69	41	33	-	80	2	3074
GN 900-120-235-75-DR-1	120	235-75	M10 x 1	M5	34	26.3	45	46	13.8	10	-	45	5	160	10	18	69	41	33	-	80	2	3240
GN 900-120-260-100-DR-1	120	260-100	M10 x 1	M5	34	26.3	45	46	13.8	10	-	45	5	160	10	18	69	41	33	-	80	2	3420
GN 900-50-95-25-DN-2	50	95-25	M6 x 1	M4	22	13	22.5	23	7	4.5	47	-	-	70	6	12	52	24	33	36	30	1.5	440
GN 900-50-120-50-DN-2	50	120-50	M6 x 1	M4	22	13	22.5	23	7	4.5	47	-	-	70	6	12	52	24	33	36	30	1.5	500
GN 900-50-145-75-DN-2	50	145-75	M6 x 1	M4	22	13	22.5	23	7	4.5	47	-	-	70	6	12	52	24	33	36	30	1.5	770
GN 900-50-170-100-DN-2	50	170-100	M6 x 1	M4	22	13	22.5	23	7	4.5	47	-	-	70	6	12	52	24	33	36	30	1.5	958
GN 900-80-145-25-DN-2	80	145-25	M8 x 1	M5	22	20.5	35.5	36	10	10	51	-	-	120	8	16	55	27	33	25	50	2	1220
GN 900-80-170-50-DN-2	80	170-50	M8 x 1	M5	22	20.5	35.5	36	10	10	51	-	-	120	8	16	55	27	33	25	50	2	1280
GN 900-80-195-75-DN-2	80	195-75	M8 x 1	M5	22	20.5	35.5	36	10	10	51	-	-	120	8	16	55	27	33	25	50	2	1360
GN 900-80-220-100-DN-2	80	220-100	M8 x 1	M5	22	20.5	35.5	36	10	10	51	-	-	120	8	16	55	27	33	25	50	2	1460
GN 900-120-185-25-DN-2	120	185-25	M10 x 1	M5	34	26.3	45	46	13.8	10	57	-	-	160	10	18	69	41	33	25	80	2	2900
GN 900-120-210-50-DN-2	120	210-50	M10 x 1	M5	34	26.3	45	46	13.8	10	57	-	-	160	10	18	69	41	33	25	80	2	3140
GN 900-120-235-75-DN-2	120	235-75	M10 x 1	M5	34	26.3	45	46	13.8	10	57	-	-	160	10	18	69	41	33	25	80	2	3300
GN 900-120-260-100-DN-2	120	260-100	M10 x 1	M5	34	26.3	45	46	13.8	10	57	-	-	160	10	18	69	41	33	25	80	2	3500
GN 900-50-95-25-DR-2	50	95-25	M6 x 1	M4	22	13	22.5	23	7	4.5	-	29	18	70	6	12	52	24	33	36	30	1.5	460
GN 900-50-120-50-DR-2	50	120-50	M6 x 1	M4	22	13	22.5	23	7	4.5	-	29	18	70	6	12	52	24	33	36	30	1.5	500
GN 900-50-145-75-DR-2	50	145-75	M6 x 1	M4	22	13	22.5	23	7	4.5	-	29	18	70	6	12	52	24	33	36	30	1.5	540
GN 900-50-170-100-DR-2	50	170-100	M6 x 1	M4	22	13	22.5	23	7	4.5	-	29	18	70	6	12	52	24	33	36	30	1.5	680
GN 900-80-145-25-DR-2	80	145-25	M8 x 1	M5	22	20.5	35.5	36	10	10	-	37	10	120	8	16	55	27	33	25	50	2	1200
GN 900-80-170-50-DR-2	80	170-50	M8 x 1	M5	22	20.5	35.5	36	10	10	-	37	10	120	8	16	55	27	33	25	50	2	1289
GN 900-80-195-75-DR-2	80	195-75	M8 x 1	M5	22	20.5	35.5	36	10	10	-	37	10	120	8	16	55	27	33	25	50	2	1360
GN 900-80-220-100-DR-2	80	220-100	M8 x 1	M5	22	20.5	35.5	36	10	10	-	37	10	120	8	16	55	27	33	25	50	2	1444
GN 900-120-185-25-DR-2	120	185-25	M10 x 1	M5	34	26.3	45	46	13.8	10	-	45	5	160	10	18	69	41	33	25	80	2	2938
GN 900-120-210-50-DR-2	120	210-50	M10 x 1	M5	34	26.3	45	46	13.8	10	-	45	5	160	10	18	69	41	33	25	80	2	3100
GN 900-120-235-75-DR-2	120	235-75	M10 x 1	M5	34	26.3	45	46	13.8	10	-	45	5	160	10	18	69	41	33	25	80	2	3273
GN 900-120-260-100-DR-2	120	260-100	M10 x 1	M5	34	26.3	45	46	13.8	10	-	45	5	160	10	18	69	41	33	25	80	2	3453

Linear Motion Components 20

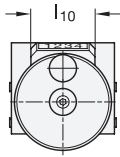

Type HN
Figure in front of decimal point refers to the movement in mm

3,5 mm protruding on size 50

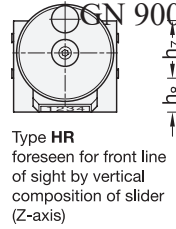
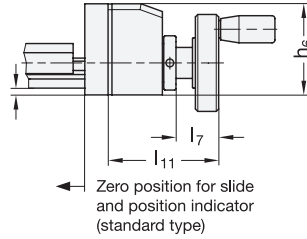

GN 900-HN/HR

Description	b	l1 - l2	d1	d2	d4	h1	h2	h3	h4	h5	h6	h7	h8	l3	l4	l5	l6	l7	l10	l11	l12	s	t		
GN 900-50-95-25-HN-1	50	95-25	M6 x 1	M4	50	13	22.5	23	7	4.5	47	-	-	70	6	12	-	22	33	57	-	30	1.5	480	
GN 900-50-120-50-HN-1	50	120-50	M6 x 1	M4	50	13	22.5	23	7	4.5	47	-	-	70	6	12	-	22	33	57	-	30	1.5	500	
GN 900-50-145-75-HN-1	50	145-75	M6 x 1	M4	50	13	22.5	23	7	4.5	47	-	-	70	6	12	-	22	33	57	-	30	1.5	540	
GN 900-50-170-100-HN-1	50	170-100	M6 x 1	M4	50	13	22.5	23	7	4.5	47	-	-	70	6	12	-	22	33	57	-	30	1.5	580	
GN 900-80-145-25-HN-1	80	145-25	M8 x 1	M5	80	20.5	35.5	36	10	10	51	-	-	120	8	16	-	31	33	66	-	50	2	1344	
GN 900-80-170-50-HN-1	80	170-50	M8 x 1	M5	80	20.5	35.5	36	10	10	51	-	-	120	8	16	-	31	33	66	-	50	2	1350	
GN 900-80-195-75-HN-1	80	195-75	M8 x 1	M5	80	20.5	35.5	36	10	10	51	-	-	120	8	16	-	31	33	66	-	50	2	1550	
GN 900-80-220-100-HN-1	80	220-100	M8 x 1	M5	80	20.5	35.5	36	10	10	51	-	-	120	8	16	-	31	33	66	-	50	2	1560	
GN 900-120-185-25-HN-1	120	185-25	M10 x 1	M5	100	26.3	45	46	13.8	10	57	-	-	160	10	18	-	40	33	75	-	80	2	1835	
GN 900-120-210-50-HN-1	120	210-50	M10 x 1	M5	100	26.3	45	46	13.8	10	57	-	-	160	10	18	-	40	33	75	-	80	2	2400	
GN 900-120-235-75-HN-1	120	235-75	M10 x 1	M5	100	26.3	45	46	13.8	10	57	-	-	160	10	18	-	40	33	75	-	80	2	3400	
GN 900-120-260-100-HN-1	120	260-100	M10 x 1	M5	100	26.3	45	46	13.8	10	57	-	-	160	10	18	-	40	33	75	-	80	2	3660	
GN 900-50-95-25-HR-1	50	95-25	M6 x 1	M4	50	13	22.5	23	7	4.5	-	29	18	70	6	12	-	22	33	57	-	30	1.5	480	
GN 900-50-120-50-HR-1	50	120-50	M6 x 1	M4	50	13	22.5	23	7	4.5	-	29	18	70	6	12	-	22	33	57	-	30	1.5	540	
GN 900-50-145-75-HR-1	50	145-75	M6 x 1	M4	50	13	22.5	23	7	4.5	-	29	18	70	6	12	-	22	33	57	-	30	1.5	550	
GN 900-50-170-100-HR-1	50	170-100	M6 x 1	M4	50	13	22.5	23	7	4.5	-	29	18	70	6	12	20	22	33	57	-	30	1.5	570	
GN 900-80-145-25-HR-1	80	145-25	M8 x 1	M5	80	20.5	35.5	36	10	10	-	37	10	120	8	16	20	31	33	66	-	50	2	1320	
GN 900-80-170-50-HR-1	80	170-50	M8 x 1	M5	80	20.5	35.5	36	10	10	-	37	10	120	8	16	20	31	33	66	-	50	2	1400	
GN 900-80-195-75-HR-1	80	195-75	M8 x 1	M5	80	20.5	35.5	36	10	10	-	37	10	120	8	16	20	31	33	66	-	50	2	1500	
GN 900-80-220-100-HR-1	80	220-100	M8 x 1	M5	80	20.5	35.5	36	10	10	-	37	10	120	8	16	20	31	33	66	-	50	2	1560	
GN 900-120-185-25-HR-1	120	185-25	M10 x 1	M5	100	26.3	45	46	13.8	10	-	45	5	160	10	18	20	40	33	75	-	80	2	3122	
GN 900-120-210-50-HR-1	120	210-50	M10 x 1	M5	100	26.3	45	46	13.8	10	-	45	5	160	10	18	20	40	33	75	-	80	2	3300	
GN 900-120-235-75-HR-1	120	235-75	M10 x 1	M5	100	26.3	45	46	13.8	10	-	45	5	160	10	18	20	40	33	75	-	80	2	3457	
GN 900-120-260-100-HR-1	120	260-100	M10 x 1	M5	100	26.3	45	46	13.8	10	-	45	5	160	10	18	24	40	33	75	-	80	2	3750	
GN 900-50-95-25-HN-2	50	95-25	M6 x 1	M4	50	13	22.5	23	7	4.5	47	-	-	70	6	12	-	22	33	57	36	30	1.5	500	
GN 900-50-120-50-HN-2	50	120-50	M6 x 1	M4	50	13	22.5	23	7	4.5	47	-	-	70	6	12	-	22	33	57	36	30	1.5	550	
GN 900-50-145-75-HN-2	50	145-75	M6 x 1	M4	50	13	22.5	23	7	4.5	47	-	-	70	6	12	-	22	33	57	36	30	1.5	580	
GN 900-50-170-100-HN-2	50	170-100	M6 x 1	M4	50	13	22.5	23	7	4.5	47	-	-	70	6	12	-	22	33	57	36	30	1.5	600	
GN 900-80-145-25-HN-2	80	145-25	M8 x 1	M5	80	20.5	35.5	36	10	10	51	-	-	120	8	16	-	31	33	66	25	50	2	1100	
GN 900-80-170-50-HN-2	80	170-50	M8 x 1	M5	80	20.5	35.5	36	10	10	51	-	-	120	8	16	-	31	33	66	25	50	2	1460	
GN 900-80-195-75-HN-2	80	195-75	M8 x 1	M5	80	20.5	35.5	36	10	10	51	-	-	120	8	16	-	31	33	66	25	50	2	1520	
GN 900-80-220-100-HN-2	80	220-100	M8 x 1	M5	80	20.5	35.5	36	10	10	51	-	-	120	8	16	-	31	33	66	25	50	2	1600	
GN 900-120-185-25-HN-2	120	185-25	M10 x 1	M5	100	26.3	45	46	13.8	10	57	-	-	160	10	18	-	40	33	75	25	80	2	3150	
GN 900-120-210-50-HN-2	120	210-50	M10 x 1	M5	100	26.3	45	46	13.8	10	57	-	-	160	10	18	-	40	33	75	25	80	2	3330	
GN 900-120-235-75-HN-2	120	235-75	M10 x 1	M5	100	26.3	45	46	13.8	10	57	-	-	160	10	18	-	40	33	75	25	80	2	3500	
GN 900-120-260-100-HN-2	120	260-100	M10 x 1	M5	100	26.3	45	46	13.8	10	57	-	-	160	10	18	-	40	33	75	25	80	2	3800	
GN 900-50-95-25-HR-2	50	95-25	M6 x 1	M4	50	13	22.5	23	7	4.5	-	29	18	70	6	12	-	22	33	57	36	30	1.5	510	
GN 900-50-120-50-HR-2	50	120-50	M6 x 1	M4	50	13	22.5	23	7	4.5	-	29	18	70	6	12	-	22	33	57	36	30	1.5	560	
GN 900-50-145-75-HR-2	50	145-75	M6 x 1	M4	50	13	22.5	23	7	4.5	-	29	18	70	6	12	-	22	33	57	36	30	1.5	580	
GN 900-50-170-100-HR-2	50	170-100	M6 x 1	M4	50	13	22.5	23	7	4.5	-	29	18	70	6	12	-	22	33	57	36	30	1.5	620	
GN 900-80-145-25-HR-2	80	145-25	M8 x 1	M5	80	20.5	35.5	36	10	10	-	37	10	120	8	16	-	31	33	66	25	50	2	1340	
GN 900-80-170-50-HR-2	80	170-50	M8 x 1	M5	80	20.5	35.5	36	10	10	-	37	10	120	8	16	-	31	33	66	25	50	2	1400	
GN 900-80-195-75-HR-2	80	195-75	M8 x 1	M5	80	20.5	35.5	36	10	10	-	37	10	120	8	16	-	31	33	66	25	50	2	1500	
GN 900-80-220-100-HR-2	80	220-100	M8 x 1	M5	80	20.5	35.5	36	10	10	-	37	10	120	8	16	20	31	33	66	25	50	2	1600	
GN 900-120-185-25-HR-2	120	185-25	M10 x 1	M5	100	26.3	45	46	13.8	10	-	45	5	160	10	18	20	40	33	75	25	80	2	3140	
GN 900-120-210-50-HR-2	120	210-50	M10 x 1	M5	100	26.3	45	46	13.8	10	-	45	5	160	10	18	20	40	33	75	25	80	2	3320	
GN 900-120-235-75-HR-2	120	235-75	M10 x 1	M5	100	26.3	45	46	13.8	10	-	45	5	160	10	18	20	40	33	75	25	80	2	3500	
GN 900-120-260-100-HR-2	120	260-100	M10 x 1	M5	100	26.3	45	46	13.8	10	-	45	5	160	10	18	24	40	33	75	25	80	2	3660	



Linear Motion Components 20