

## Adapter flanges for swing clamps GN 875 / GN 876

### SPECIFICATION

Aluminum **AL**  
hard anodized **HE**  
wear-resistant surface  
Socket cap screw DIN 912  
Steel, zinc plated, blue passivated  
Washer ISO 7092  
Steel, zinc plated, blue passivated

### INFORMATION

Adapter flanges GN 875.4 are designed as accessories to swing clamps GN 875 (see page ) / GN 876 (see page ) and serve as adapter for mounting custom clamping arms.  
The angle orientation of the clamping arm can be set arbitrarily during mounting on the swing clamp. When tightening the screw, the piston rod must not experience any torque. The clamping arm must therefore be held to prevent twisting.  
Included are a socket cap screw DIN 912 and a washer ISO 7092 for fastening to the swing clamp.

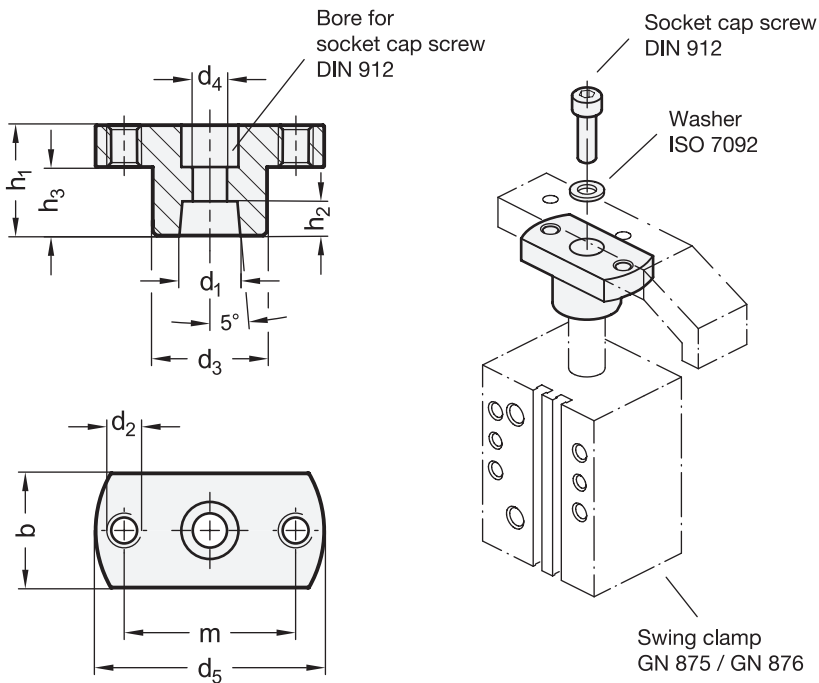
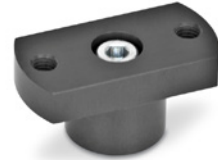

### GN 875.4

Description	for swing clamps Size	d1	m	b	d2	d3	d4	d5	h1	h2	h3	
GN 875.4-AL-14-38-HE	25	14	38	25	M 6	25	8.5	50	24.5	8	12	4
GN 875.4-AL-16-45-HE	32 / 40	16	45	30	M 8	30	9	60	29	9	18	4
GN 875.4-AL-20-48-HE	50 / 63	20	48	32	M 8	32	10.5	65	30	10	18	4