

# GN 872

Clamping jaws blank

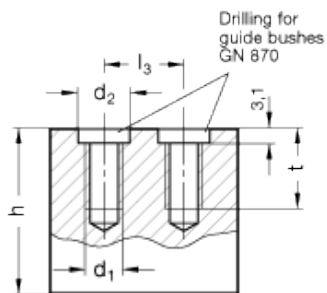

Mounting examples

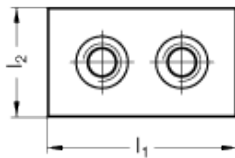
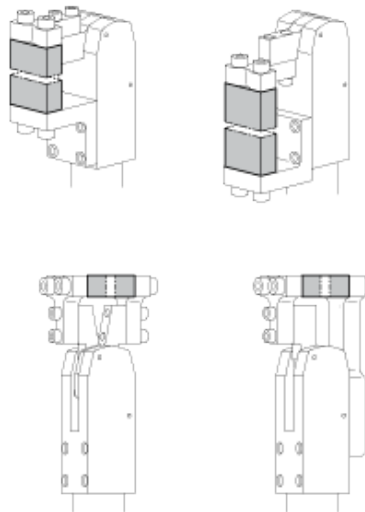

## technical informations

### Material

Black-oxide steel C45.

### Accessories on request

Guide bushes [GN 870](#) to be ordered separately.

### Features and applications

Clamping jaws blank GN 872 are manufactured to meet the dimensions of the accessories for clamping arms and static holders. In general they are re-worked into the required shape.

Assembly examples

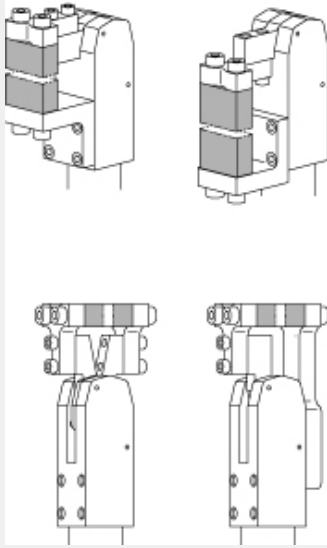

Standard Elements	Main dimensions							Weight
Description	$l_1$	h	d	$d_{2\text{H8/h6}}$	$l_2$	$l_{3\pm0.01}$	t	g
GN 872-30-25	30	25	M6	9	13	17	13	70
GN 872-30-50	30	50	M6	9	13	17	13	150
GN 872-40-35	40	35	M8	11	17	23	17	180
GN 872-40-70	40	70	M8	11	17	23	17	370
GN 872-50-45	50	45	M10	13	20	30	20	350
GN 872-50-80	50	80	M10	13	20	30	20	620
GN 872-60-50	60	50	M10	13	20	40	20	470
GN 872-60-85	60	85	M10	13	20	40	20	800



STANDARD MACHINE ELEMENTS WORLDWIDE