

GN 835

Wing screws

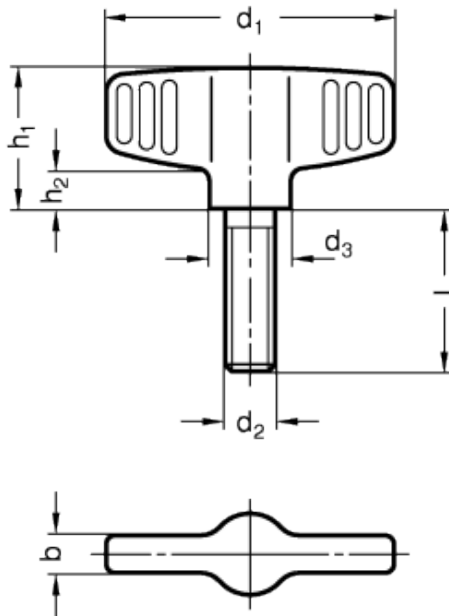

INOX
Stainless Steel



technical informations

Material

Precision casting AISI CF-8 stainless steel, sandblasted matte finish.

Assembly

Precision casting AISI CF-8 stainless steel threaded pin.

Features and applications

These wing screws allow high tightening torque values.

Stainless steel, thanks to its high resistance to corrosion, allows the application of these wing nuts on machines and equipment in those sectors where laws or particular hygienic, climatic and environmental factors make it mandatory to use corrosion

resistant materials.

Standard Elements	Main dimensions					Threaded pin		Weight
Description	d ₁	d ₃	b	h ₁	h ₂	d ₂	l	g
GN 835-46-M6-16-MT	46	13	6	22.5	6	M6	16	40
GN 835-46-M6-20-MT	46	13	6	22.5	6	M6	20	41
GN 835-46-M6-25-MT	46	13	6	22.5	6	M6	25	42
GN 835-46-M8-16-MT	46	13	6	22.5	6	M8	16	60
GN 835-46-M8-20-MT	46	13	6	22.5	6	M8	20	61
GN 835-46-M8-25-MT	46	13	6	22.5	6	M8	25	65
GN 835-58-M8-20-MT	58	16	7	26.5	7	M8	20	64
GN 835-58-M8-25-MT	58	16	7	26.5	7	M8	25	63
GN 835-58-M8-30-MT	58	16	7	26.5	7	M8	30	85
GN 835-58-M10-20-MT	58	16	7	26.5	7	M10	20	80
GN 835-58-M10-25-MT	58	16	7	26.5	7	M10	25	82
GN 835-58-M10-30-MT	58	16	7	26.5	7	M10	30	85



ELESA and GANTER models all rights reserved in accordance with the law. Always mention the source when reproducing our drawings.

STANDARD MACHINE ELEMENTS WORLDWIDE