

GN 822

Mini indexing plungers

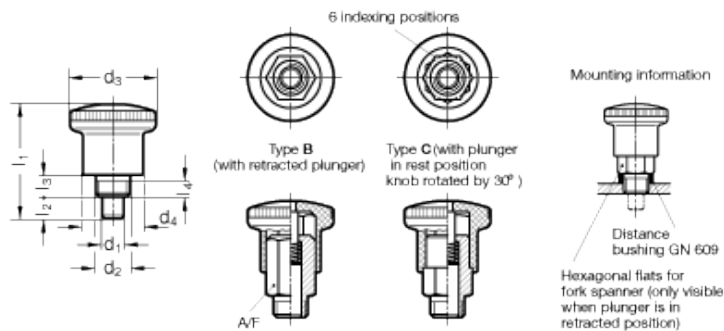

technical informations

Specification

Type

- Type B: without rest Position, with plastic knob
- Type C: with rest Position

Steel ST

zinc plated, blue passivated

Plunger

Stainless Steel AISI 303

Spring

Stainless Steel AISI 301

Knob Plastic (Polyamide PA)

- black, matt
- red, RAL 3000 RT
- not removable

Information

Mini indexing plungers GN 822 are distinguished for their small dimensions. They have been designed for installation in thin walled sheet metal constructions.

They are inserted into position by holding them by the serrated knob. The spanner flats on the lock nut are revealed when retracting the pin, so that the mini indexing plunger can be easily tightened by means of a fork spanner.

With type C the knob can be turned by 30° and a notch keeps the knob in this position.

Instructions of use

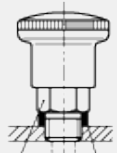

Distance bushing GN 609

Hexagonal flats faces
(visible only when plunger is
in retracted position)

Accessories on request (For sufficient quantities)

GN 609 black-oxide steel distance bushings are available for making up for the length of the threading in case the plunger is assembled on thin sheets.

Standard Elements	Main dimensions									Spring pressure in N \approx		Weight
	Description	d_1 0/-0.06	d_2	d_3	d_4	l_1	l_2 min.	l_3	l_4 min.	A/F	Preload	
GN 822-4-B-ST	4	M8x0.75	21	15	26.5	5	5	3.5	10	4.5	12	13
GN 822-5-B-ST	5	M8x0.75	21	15	26.5	5	5	3.5	10	4.5	12	14
GN 822-6-B-ST	6	M10x1	25	18	34	7	7	4.5	12	5	18	24
GN 822-7-B-ST	7	M10x1	25	18	34	7	7	4.5	12	5	18	25
GN 822-4-C-ST	4	M8x0.75	21	15	26.5	5	5	3.5	10	4.5	12	14
GN 822-5-C-ST	5	M8x0.75	21	15	26.5	5	5	3.5	10	4.5	12	14
GN 822-6-C-ST	6	M10x1	25	18	34	7	7	4.5	12	5	18	24
GN 822-7-C-ST	7	M10x1	25	18	34	7	7	4.5	12	5	18	25
GN 822-4-B-ST-RT	4	M8x0.75	21	15	26.5	5	5	3.5	10	4.5	12	13
GN 822-5-B-ST-RT	5	M8x0.75	21	15	26.5	5	5	3.5	10	4.5	12	14
GN 822-6-B-ST-RT	6	M10x1	25	18	34	7	7	4.5	12	5	18	24
GN 822-7-B-ST-RT	7	M10x1	25	18	34	7	7	4.5	12	5	18	25
GN 822-4-C-ST-RT	4	M8x0.75	21	15	26.5	5	5	3.5	10	4.5	12	14
GN 822-5-C-ST-RT	5	M8x0.75	21	15	26.5	5	5	3.5	16	4.5	12	14
GN 822-6-C-ST-RT	6	M10x1	25	18	34	7	7	4.5	12	5	18	24
GN 822-7-C-ST-RT	7	M10x1	25	18	34	7	7	4.5	12	5	18	25



ELESA and GANTER models all rights reserved in accordance with the law. Always mention the source when reproducing our drawings.

STANDARD MACHINE ELEMENTS WORLDWIDE