

Type NL

Type NLC

Type PL

Operating principle



ROSTFREI
Inox
Stainless
Steel

2 Type

- NL** U-bar version, with two flanged washers
- NLC** U-bar version, with two flanged washers and clamping screw GN 708.1
- PL** Solid bar version, with clasp

1

Size	Steel	Stainless Steel	F _H in N Holding capacity	a ≈	b ₁	b ₂	b ₃	b ₄	d ₁	d ₂	h ₁ ≈	h ₂	h ₃
75	75	75	900	20	28	8	4	5,3	M 5	4,5	45,5	29	11
130	130	130	1000	32	36	10	5	6,3	M 6	5,6	64,5	44	16
230	230	230	1700	37	44	12	6	8,5	M 8	6,6	75,5	51	18
355	-	-	1800	58	60	14	7	10,5	M 10	8,6	102	69,5	22
455	-	-	3200	65	70	18	10	12,5	M 12	8,7	120	80,5	26

Size	Steel	Stainless Steel	h ₄	h ₅ max.	l ₁ ≈	l ₂ ≈	l ₃ ≈	l ₄ max.	l ₅	m ₁	m ₂	m ₃	r ≈	s	w Adjustable range
75	75	75	19	14	118	68	40	49,5	45	13,5	3,5	5	43	4	15
130	130	130	25,5	27,5	172	92	53	64	55	26	5,8	8,8	62	5	17,5
230	230	230	30	27	196	109	63,5	78	68	26	6,5	9	73	6	20
355	-	-	37	43	270	161	96	115	77	41	7,5	9,6	110	7	19
455	-	-	43	48	306	186	116	135	100	41,5	11	12,5	128	10	33

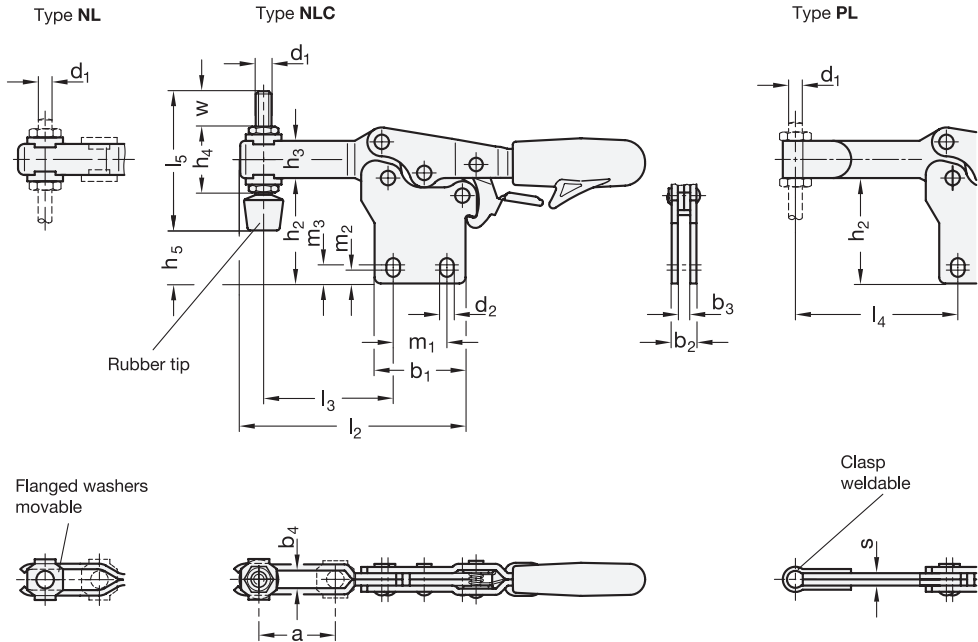

Specification

- Steel —
 - Case-hardened Steel C10 zinc plated, blue passivated
 - Bearing pins tempered
 - Bearing rivets (for size 355 and up) case-hardened
- Stainless Steel **NI**
AISI 304
- All moving parts lubricated with special grease
- Hand grip High quality, oil resistant red plastic
- Clamping screw GN 708.1, type A
 - Steel, zinc plated / Stainless Steel, AISI 304
 - Rubber tip 85 Shore A
- *Stainless Steel characteristics → Page 1489*
- **RoHS**

Accessory

- Clamping screws → *Page 585 ff.*
- Holders for clamping screws GN 801 (for toggle clamps) (for type NL) → *Page 590*
- Holders for clamping screws GN 809 (for toggle clamps) (for type PL) → *Page 591*
- Clamping arm extenders GN 801.1 (for type NL) → *New products*
- Clamping arm extenders GN 801.2 (for type NL) → *New products*
- Clamping arm extenders GN 809.1 (for type PL) → *New products*

Information

GN 820.4 toggle clamps have a safety function whereby, during closing, a spring loaded safety hook latch ensures a secure locking connection. It prevents the inadvertent unlocking of the clamp due to vibrations or an accidental attempt of loosening / opening of the clamp. To open and release the clamp, pull up on the finger grip to disengage the safety hook latch mechanism (one hand operation).

They work according to the toggle principle: lever and clamping bar move in the opposite direction. They require less space for the clamping action.

Toggle clamps in the U-bar version with two flanged washers (type NL) can accommodate an application specific clamping screw. A clamping screw with neoprene rubber tip is also included for type NLC.

Toggle clamps in the type PL version can either be utilized by welding the clasp which can then accommodate an application specific hold-down fastener component, or by utilizing the bar in conjunction with the GN 809 holders for clamping screws to hold the work piece in place.

How to order (Steel)	
1	Size
GN 820.4-455-NL	
2	Type

How to order (Stainless Steel)	
1	Size
GN 820.4-130-PL-NI	
2	Type
3	Material

