

GN 817.1

Indexing plungers



Type B

Type C

(Knob rotated by 90°)

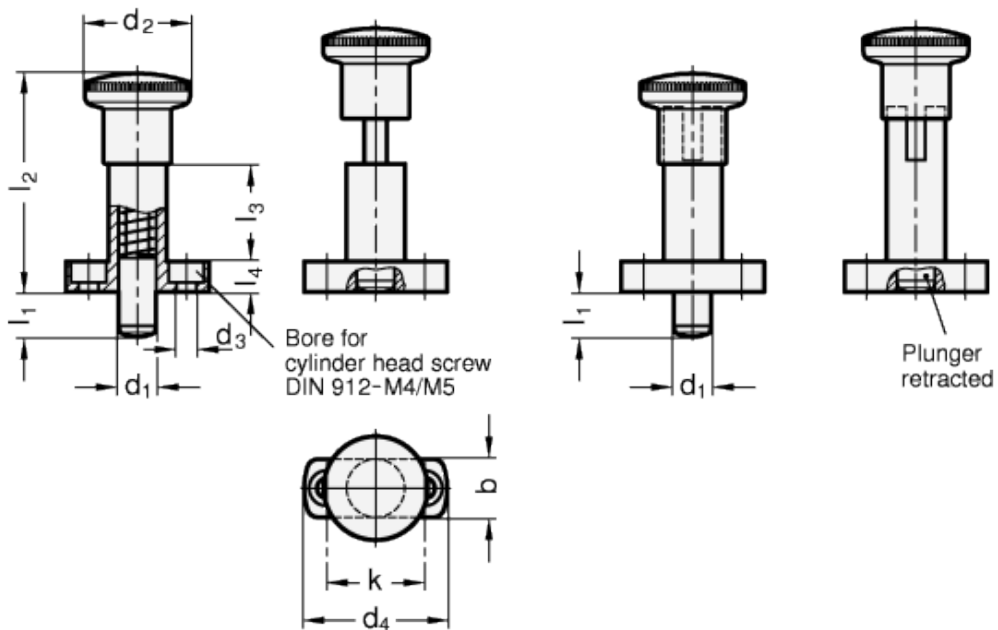

technical informations

Specification

Types

- Type B: without rest position
- Type C: with rest position

Guide

Zinc die casting

plastic coated

black, textured finish

Pin
Stainless Steel
- AISI 303

Knob Plastic
Technopolymer (Polyamide PA)
- black, matt
- not removable

Information

Indexing plungers GN 817.1 (Type C) are used for such applications where the plunger has to stay in its retracted position. To achieve this, the knob is rotated by 90° degrees after being retracted. A notch keeps the plunger in this position.

On request

- Indexing plungers with T-Handle

Standard Elements	Main dimensions										Weight	
Description	d_1 销头 -0.02/-0.04 / 孔 +0.10/+0.03	l_1	b	d_2	d_3	d_4	k	l_2	l_3	l_4	初始	未段
GN 817.1-6-6-B	6	6	13	23	4.3	34	22	48	22	6	6.5	19
GN 817.1-6-9-B	6	9	13	23	4.3	34	22	48	22	6	6	25
GN 817.1-8-8-B	8	8	16	28	5.3	38	26	58	26	8	8.5	26
GN 817.1-8-12-B	8	12	16	28	5.3	38	26	58	26	8	8.5	28
GN 817.1-10-12-B	10	12	16	28	5.3	38	26	58	26	8	9.5	38
GN 817.1-6-6-C	6	6	13	23	4.3	34	22	48	22	6	6.5	19
GN 817.1-6-9-C	6	9	13	23	4.3	34	22	48	22	6	6	25
GN 817.1-8-8-C	8	8	16	28	5.3	38	26	58	26	8	8.5	26
GN 817.1-8-12-C	8	12	16	28	5.3	38	26	58	26	8	8.5	28
GN 817.1-10-12-C	10	12	16	28	5.3	38	26	58	26	8	9.5	38



STANDARD MACHINE ELEMENTS WORLDWIDE