

# GN 815

Threaded plungers with screwdriver slotted head

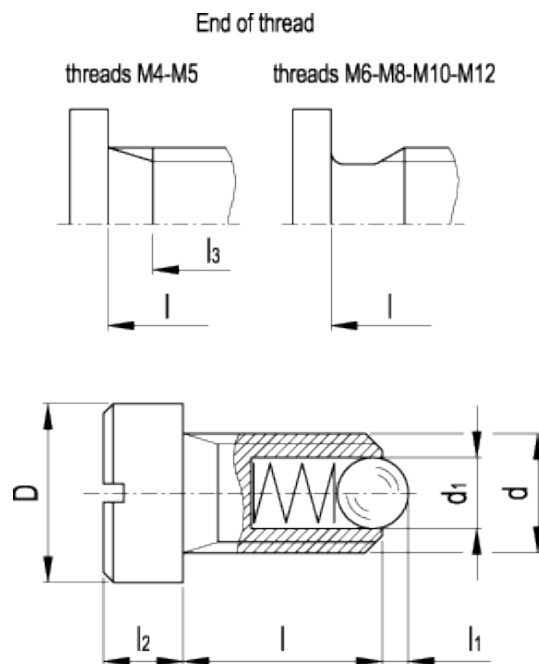

## technical informations

### Body

Black-oxide steel, screwdriver slotted head.

### Ball and spring

Hardened steel ball, steel spring.

### Features

The screwdriver slot on the head of the plunger is also useful to provide an indication of the position of the blocked element.

Standard Elements	Main dimensions							Spring pressure		Weight
Description	d	d <sub>1</sub>	D	l	l <sub>1</sub>	l <sub>2</sub>	l <sub>3</sub>	Preload [N~]	Max. load [N~]	g
GN 815-M4-ST	M4	2.5	6	6.5	0.8	3	5	8	14	2
GN 815-M5-ST	M5	3	8	8.5	0.9	4	6.7	8	14	5
GN 815-M6-ST	M6	3.5	10	9	1	5	-	11	18	6
GN 815-M8-ST	M8	4.5	13	11	1.5	5.5	-	18	31	10
GN 815-M10-ST	M10	6	16	14	2	6	-	24	45	15
GN 815-M12-ST	M12	8	18	15	2.5	7	-	26	49	25



ELESA and GANTER models all rights reserved in accordance with the law. Always mention the source when reproducing our drawings.

**STANDARD MACHINE ELEMENTS WORLDWIDE**