

# GN 812

Vertical clamps

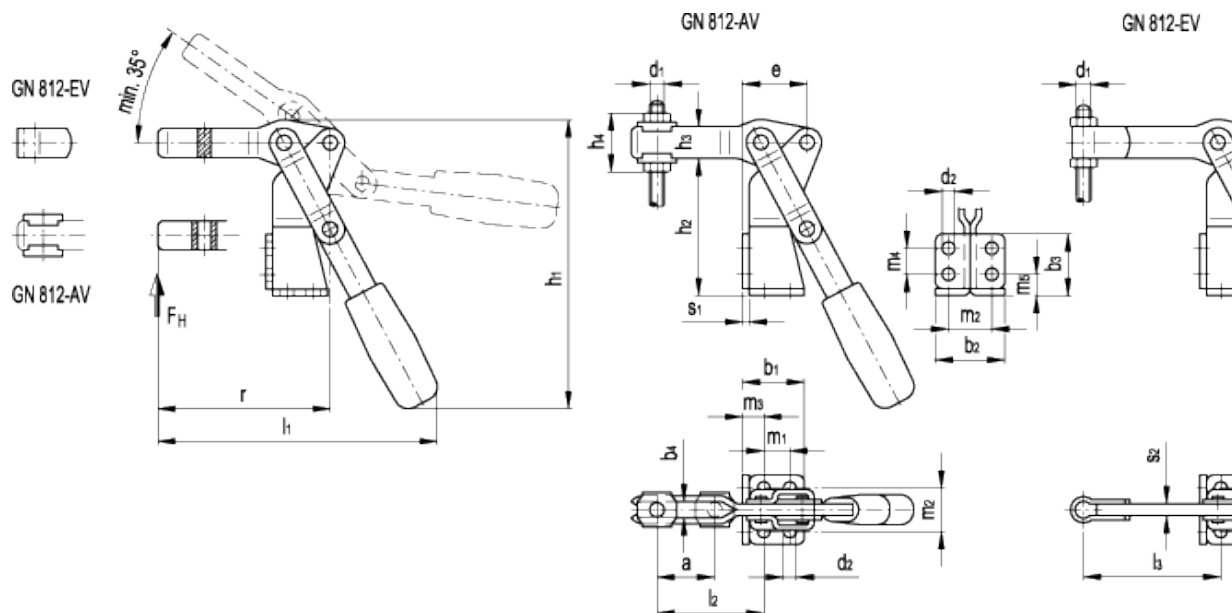

## technical informations

### Sheet body and metal parts

Zinc-plated case-hardened steel C10, blue passivated.

- Version AV: forked clamping arm with two stepped side washers.
- Version EV: solid clamping arm with bolt retainer for welding.

### Bearing pins

Hardened and tempered steel.

### Bearing rivets

Case-hardened steel.

### Handle

Oil resistant, solid plastic, red colour.

*Features and applications*

All moving parts are lubricated with special grease.  
 Worth pointing out is that the vertical clamp GN 812 can be mounted in two planes and requires less space for the clamping movement since the clamping arm and the operating lever are moving in opposite directions.  
 Furthermore the clamping arm is stamped from solid and re-inforced for heavy duty application.

*Order information*

Clamping bolts to be ordered separately.

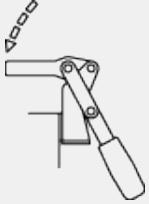

Standard Elements	Main dimensions																					Holding force	Weight		
Description	a	b <sub>1</sub>	b <sub>2</sub>	b <sub>3</sub>	b <sub>4</sub>	d <sub>1</sub>	d <sub>2</sub>	e	h <sub>1</sub>	h <sub>2</sub>	h <sub>3</sub>	h <sub>4</sub>	l <sub>1</sub>	l <sub>2</sub>	l <sub>3 max</sub>	m <sub>1</sub>	m <sub>2</sub>	m <sub>3</sub>	m <sub>4</sub>	m <sub>5</sub>	r	s <sub>1</sub>	s <sub>2</sub>	FH [N]	g
GN 812-200-AV	34	35	38	35	8.5	M8	6.5	37	154	76	17	34	158	59	-	16	26	11	16	11	97	3	-	2200	420
GN 812-300-AV	42	48	48	51	10.3	M10	8.5	46	198	108	20	41	194	74	-	28	30	11.5	30	12	121	3	-	2700	800
GN 812-200-EV	-	35	38	35	-	M8	6.5	37	154	76	17	34	158	-	76	16	26	11	16	11	97	3	6	2200	420
GN 812-300-EV	-	48	48	51	-	M10	8.5	46	198	108	20	41	194	-	76	28	30	11.5	30	12	121	3	8	2700	800



STANDARD MACHINE ELEMENTS WORLDWIDE