

ROSTFREI  
Inox  
Stainless  
Steel

**2 Type**

- BL** U-bar version, with two flanged washers
- BLC** U-bar version, with two flanged washers and GN 708.1 spindle assembly
- FL** Solid bar version, with clasp, for welding

**Operating principle**

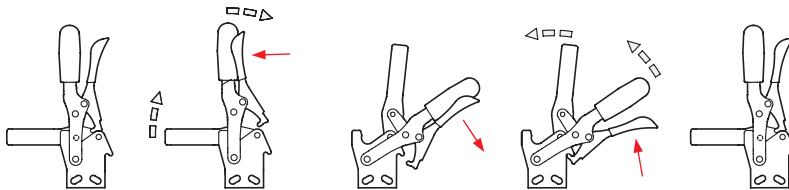

Size	F <sub>H</sub> in N Holding capacity	a ≈	b <sub>1</sub>	b <sub>2</sub>	b <sub>3</sub>	b <sub>4</sub>	d <sub>1</sub>	d <sub>2</sub> ≈	h <sub>1</sub> ≈	h <sub>2</sub>	h <sub>3</sub>	h <sub>4</sub>	h <sub>5</sub> max.
130	1050	28	35	10	5	6,2	M 6	5,5	156	41,5	16	25,5	25
230	2000	40	43	12	6	8,5	M 8	6,5	183	48	18	30	24

Size	l <sub>1</sub> ≈ Type BL Type BLC	Type FL	l <sub>2</sub> ≈	l <sub>3</sub> max.	l <sub>4</sub>	m <sub>1</sub>	m <sub>2</sub>	m <sub>3</sub>	m <sub>4</sub>	r ≈	s	w Adjustable range
130	85	86	42	54	55	12,5	19	6,5	7,5	79	5	17,5
230	110,5	112	58	73	68	18	21	6,5	6,5	104	6	20

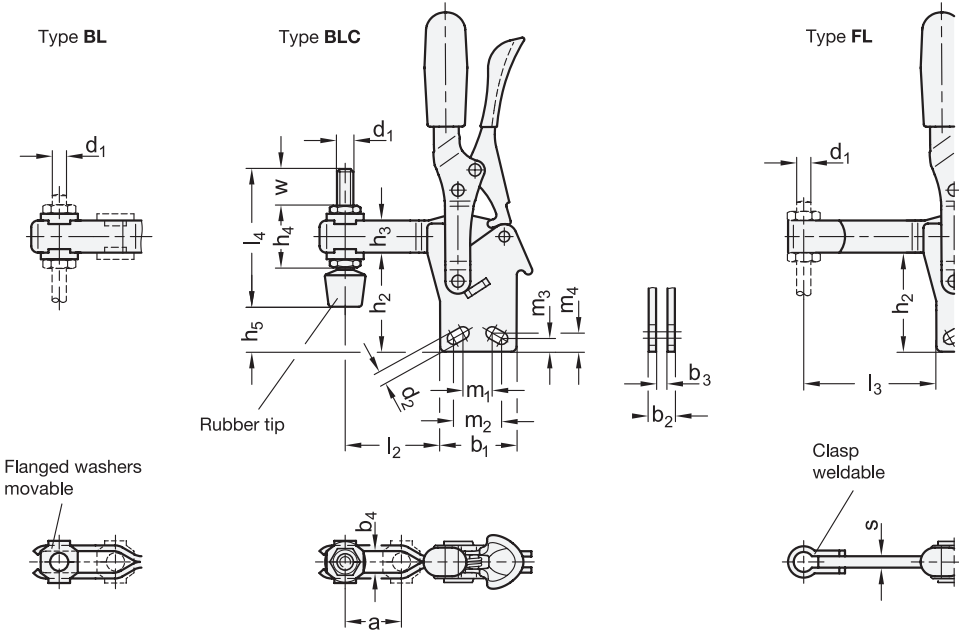

**Specification**

- Steel —
  - Case-hardened Steel C 10 zinc plated, blue passivated
  - Bearing pins tempered
  - Bearing rivets case-hardened

---

- Stainless Steel NI

AISI 304

---

- All moving parts lubricated with special grease

---

- Hand grip
  - High quality, oil resistant, red plastic

---

- Clamping screw GN 708.1, type A
  - Steel, zinc plated / Stainless Steel AISI 304
  - Rubber tip 85 Shore A

---

- *Stainless Steel characteristics* → Page 1489
- **RoHS**

**Accessory**

- Clamping screws → Page 585 ff.
- Holders for clamping screws GN 801 (for type BL) → Page 590
- Holders for clamping screws GN 809 (for type FL) → Page 591
- Clamping arm extenders GN 801.1 (for type AL) → *New products*
- Clamping arm extenders GN 801.2 (for type EL) → *New products*
- Clamping arm extenders GN 809.1 (for type EL) → *New products*

**Information**

GN 810.4 toggle clamps are latched in both end positions. In the clamped position, this prevents unintentional opening or opening caused by vibrations; and in the open position, it prevents self-closing of the toggle clamp, such as due to an extended clamping arm. The latching can be disabled with a single hand to allow for opening / closing.

They work according to the toggle principle: lever and clamping bar move in the same direction. In the clamped position the operating lever is in its vertical position.

Toggle clamps in the U-bar version with two flanged washers (type BL) can accommodate an application specific clamping screw. A clamping screw with neoprene rubber tip is also included for type BLC.

Type FL version can either be utilized by welding the clasp which can then accommodate an application specific hold-down fastener component, or by utilizing the bar in conjunction with the GN 809 holders for clamping screws to hold the work piece in place.

see also...

- *General information for toggle clamps* → Page 500
- *Toggle clamps GN 910.1 („Longlife“)* → Page 508
- *Toggle clamps GN 810.3 (with horizontal mounting base)* → *New products*

How to order (Steel) <div style="display: flex; justify-content: space-around; margin-top: 5px;"> <span style="color: red;">1</span> <span style="color: red;">2</span> </div>	1 Size
<b>GN 810.4-230-BL</b>	2 Type

How to order (Stainless Steel) <div style="display: flex; justify-content: space-around; margin-top: 5px;"> <span style="color: red;">1</span> <span style="color: red;">2</span> <span style="color: red;">3</span> </div>	1 Size
<b>GN 810.4-130-FL-NI</b>	2 Type
	3 Material

1.1  
1.2  
1.3  
1.4  
2.1  
2.2  
2.3  
2.4

