

Type UL

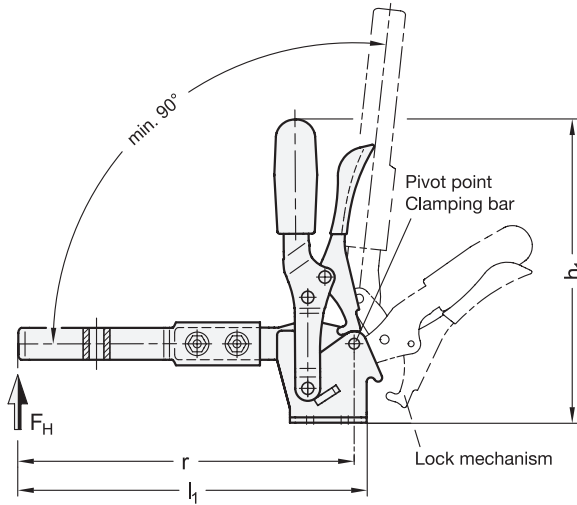

Type ULC

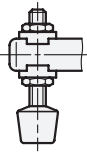

**2 Type**

**UL** Clamping arm extended, with slotted hole and with two flanged washers

**ULC** Clamping arm extended, with slotted hole, two flanged washers and clamping screw GN 708.1

**Operating principle**

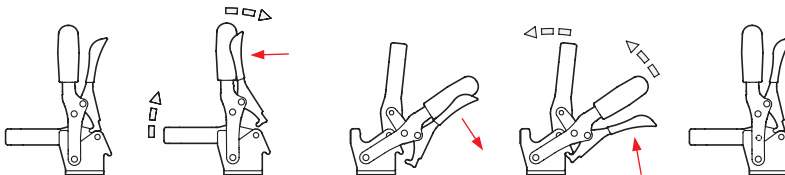

**1**

Size	F <sub>H</sub> in N Holding capacity	a ≈	b <sub>1</sub>	b <sub>2</sub>	b <sub>3</sub>	d <sub>1</sub>	d <sub>2</sub> ≈	h <sub>1</sub> ≈	h <sub>2</sub>	h <sub>3</sub>	h <sub>4</sub>	h <sub>5</sub> max.
130	500	67,5	35	42	6,3	M 6	5,5	142	28	16	25,5	11,3
230	1000	71,5	43	45	8,2	M 8	6,5	168	33,5	18	30	9,5

Size	l <sub>1</sub> ≈	l <sub>2</sub> ≈	l <sub>3</sub>	m <sub>1</sub>	m <sub>2</sub>	m <sub>3</sub>	m <sub>4</sub>	r ≈	s	w Adjustable range
130	164	121	55	12,5	19	27	29	158	2,5	17,5
230	198	145,5	68	19,5	19,5	32	32	191	3	20

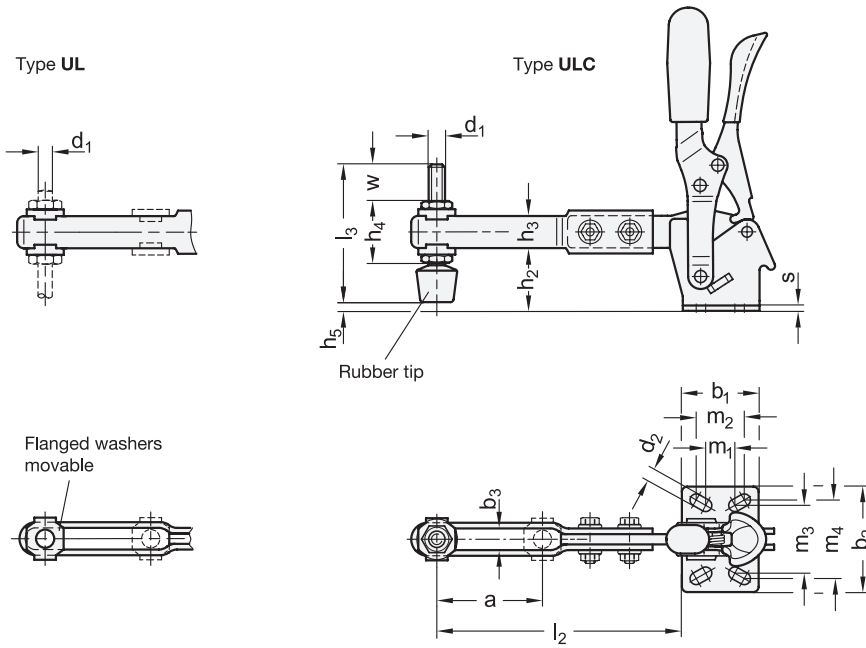

## Specification

- Steel
  - Case-hardened Steel C10 zinc plated, blue passivated
  - Bearing pins tempered
  - Bearing rivets case-hardened
- All moving parts lubricated with special grease
- Hand grip
  - High quality, oil resistant, red plastic
- Clamping screw GN 708.1, type A
  - Steel, zinc plated
  - Rubber tip
  - Hardness 85 Shore A

## RoHS

## Accessory

- Clamping screws → Page 585 ff.
- Holders for clamping screws GN 801 → Page 590
- Clamping arm extenders GN 801.1 → New products
- Clamping arm extenders GN 801.2 → New products

## Information

GN 810.3 toggle clamps have a safety function whereby, during closing, a spring loaded safety hook latch ensures a secure locking connection. It prevents the inadvertent unlocking of the clamp due to vibrations or an accidental attempt of loosening / opening of the clamp. To open and release the clamp, pull up on the finger grip to disengage the safety hook latch mechanism (one hand operation).

They work according to the toggle principle: lever and clamping bar move in the same direction. In the clamped position the operating lever is in its vertical position.

Toggle clamps in the U-bar version with two flanged washers (type UL) can accommodate an application specific clamping screw. A clamping screw with neoprene rubber tip is also included for type ULC.

### see also...

- General information for toggle clamps → Page 500
- Toggle clamps GN 910 („Longlife“) → Page 506
- Toggle clamps GN 810.4 (with vertical mounting base, with extended clamping arm) → New products

### How to order

GN810.3-230-UL

- |   |      |
|---|------|
| 1 | Size |
| 2 | Type |

