

Type A

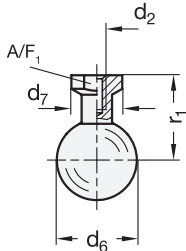

Type B

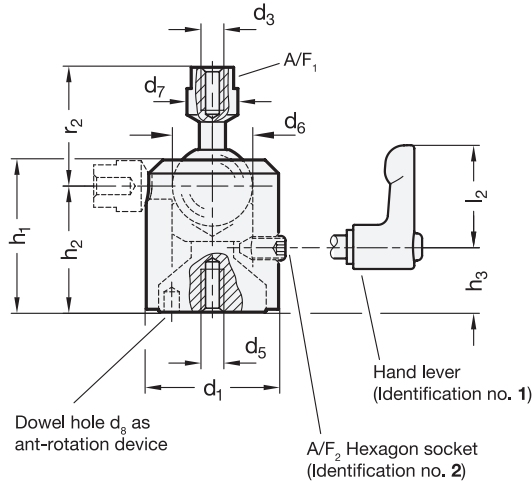
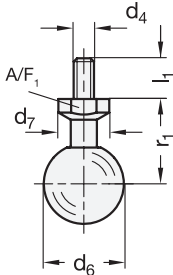

**3 Type**

- A** Ball with female thread
- B** Ball with male thread

**4 Identification no.**

- 1 Clamping with adjustable hand lever
- 2 Clamping with set screw

**1**

**2**

**2**

**2**

d <sub>1</sub>	d <sub>2</sub> * Type A	r <sub>1</sub>	d <sub>3</sub> ** Type A		r <sub>2</sub>	d <sub>4</sub> Type B		r <sub>1</sub>	l <sub>1</sub>
				Inch thread			Inch thread		
23	M 4	17,3	M 5	-	24,8	M 5	-	17,3	8
23	-	-	-	1/4 (≅ 1/4-20)	24,8	M 6	1/4 (≅ 1/4-20)	17,3	10
31	M 5	21,5	M 6	1/4 (≅ 1/4-20)	32,5	M 6	1/4 (≅ 1/4-20)	21,5	10
31	-	-	-	-	32,5	M 8	-	21,5	12
39	M 5	25,5	M 6	-	36,2	M 6	-	25,5	10
39	-	-	M 8	3/8 (≅ 3/8-16)	40,5	M 8	3/8 (≅ 3/8-16)	25,5	12
49	M 8	30,8	-	3/8 (≅ 3/8-16)	44,8	M 8	3/8 (≅ 3/8-16)	30,8	12
49	-	-	M 10	-	51,8	M 10	-	30,8	15

**1**

d <sub>1</sub>	d <sub>5</sub> ***	d <sub>6</sub>	d <sub>7</sub>	d <sub>8</sub>	h <sub>1</sub>	h <sub>2</sub>	h <sub>3</sub>	k	l <sub>2</sub>	m	A/F <sub>1</sub>	A/F <sub>2</sub>	recommended tightening torque of the clamping (Identification no.) in Nm ≈	resulting stop torque on the ball in Nm ≈
23	M 5	14	11	2,5	26,6	21,7	10,6	32	22	7	9	2,5	1,5	4,5
31	M 6	18	14	3,5	35,5	29,6	14,9	36	22	9	12	3	2,5	6,5
39	M 8	24	15	4,5	45	37,2	18,9	44	30	12	13	4	4	16
49	M 8	28	19,5	4,5	56	46,1	24	49	30	16	17	4	4	20

\* usable depth of thread min. 1,5 x d<sub>2</sub> \*\* usable depth of thread min. 1,5 x d<sub>3</sub> \*\*\* usable depth of thread min. 1,5 x d<sub>5</sub>

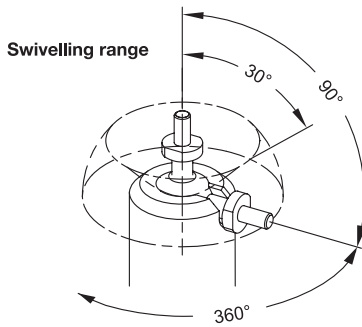
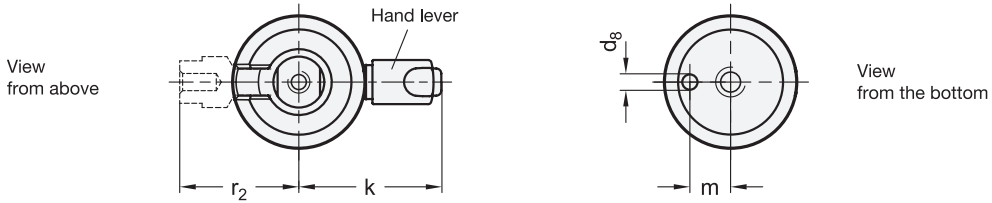

Swivel ball joint GN 784

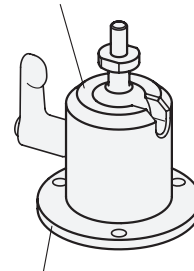

Flange 784.1

**Specification**

- Housing  
Aluminum  
anodized black
- Base plate, ball  
Aluminum, blank
- Adjustable hand lever (Identification no. 1)  
- Zinc die casting  
plastic coated  
silver, RAL 9006, textured finish  
- Threaded stud and retaining screw  
Stainless Steel AISI 303
- Set screw (Identification no. 2)  
Stainless Steel AISI 304
- *Stainless Steel characteristics* → Page 1489
- RoHS

ELS

**On request**

- Clamping with star knob DIN 6335

**Information**

GN 784 Swivel ball joints allow precise and variable adjustment of the ball pivot within the rotation range. This is a particular advantage when adjusting scanners, cameras, lighting, monitors, etc.

Thanks to the efficient clamping mechanism, only small amounts of torque on the clamping screw result in comparatively strong clamping pressure on the ball. This force is easily applied by the clamping lever (Identification no. 1).

The ball joint can be mounted from below with the  $d_5$  internal thread and together with the GN 784.1 flange, available as an accessory, using three through-holes from above.

For a permanent high stop torque, the contact surfaces of the balls must be kept free of grease. Exceeding the recommended tightening torque increases the securing of the ball joint in its end position, but may result in increased wear and potential failure of the clamping mechanism.

see also...

- *Flanges GN 784.1* → Page 1266

<p>How to order (with female thread)</p> <p>1 2 3 4 5</p> <p><b>GN 784-39-3/8-A-1-ELS</b></p>	1	$d_1$
	2	$d_3$ ( $d_2$ )
	3	Type
	4	Identification no.
	5	Finish

<p>How to order (with male thread)</p> <p>1 2 3 4 5</p> <p><b>GN 784-49-M8-B-2-ELS</b></p>	1	$d_1$
	2	$d_4$
	3	Type
	4	Identification no.
	5	Finish

3.1  
3.2  
3.3  
3.4  
3.5  
3.6  
3.7  
3.8  
3.9

