

# GN 736.1

Control handwheels

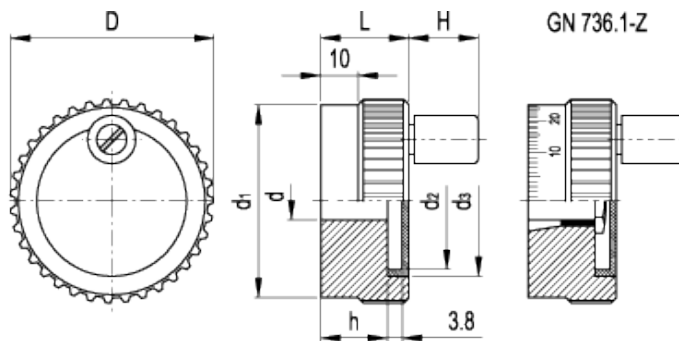

## technical informations

### Material

Knurled aluminium profile, anodised.

### Colour

Black.

### Cap

Acetal resin based (POM) technopolymer, light grey colour. Resistant to solvents, oils, greases and other chemical agents.

### Assembly

- Execution B: H8 reamed hole.
- Execution K: H8 reamed hole and keyway in compliance with [DIN 6885/1 P9 tolerance](#).
- Execution Z: with collet and graduated ring (scale 0...90, 100 graduations).

### Handle

- Execution A: without handle.
- Execution D: with revolving handle in polyamide based (PA) technopolymer, black colour, glossy finish.

*Special executions on request (For sufficient quantities)*

- On the surface of the cap words, marks, graphic symbols, etc... can be tampoprinted in colours.
- On the plain surface of the handwheel precision graduations (see [Graduations](#) ) can be laser-engraved.

Standard Elements	Main dimensions					Mounting hole		Handle		Weight
	Description	D	L	d <sub>1</sub>	d <sub>2</sub>	d <sub>3</sub>	d <sub>H8</sub>	h	Ø	
GN 736.1-52-B10-A	52	23	50	37	39.5	10	17	-	-	100
GN 736.1-52-B10-D	52	23	50	37	39.5	10	17	13	18	113
GN 736.1-52-K10-A	52	23	50	37	39.5	10	17	-	-	99
GN 736.1-52-K10-D	52	23	50	37	39.5	10	17	13	18	112
GN 736.1-62-B10-A	62	23	60	47	49.5	10	17	-	-	142
GN 736.1-62-B10-D	62	23	60	47	49.5	10	17	14	20	156
GN 736.1-62-K10-A	62	23	60	47	49.5	10	17	-	-	141
GN 736.1-62-K10-D	62	23	60	47	49.5	10	17	14	20	155
GN 736.1-52-Z10-A	52	23	50	37	39.5	10	17	-	-	111
GN 736.1-52-Z10-A-S	52	23	50	37	39.5	10	17	-	-	110
GN 736.1-52-Z10-D	52	23	50	37	39.5	10	17	13	18	120
GN 736.1-52-Z10-D-S	52	23	50	37	39.5	10	17	13	18	121
GN 736.1-62-Z10-A	62	23	60	47	49.5	10	17	-	-	154
GN 736.1-62-Z10-A-S	62	23	60	47	49.5	10	17	-	-	154
GN 736.1-62-Z10-D	62	23	60	47	49.5	10	17	14	20	165
GN 736.1-62-Z10-D-S	62	23	60	47	49.5	10	17	14	20	167

This product had the following design awards:



ELESA and GANTER models all rights reserved in accordance with the law. Always mention the source when reproducing our drawings.

STANDARD MACHINE ELEMENTS WORLDWIDE