

Semi-split Stainless Steel- Shaft collars

with flange holes

SPECIFICATION

Types

- Type **A**: with two through holes
- Type **B**: with two countersunk holes for socket head cap screws
- Type **C**: with two tapped holes

Stainless Steel **NI**

Sintered Steel AISI 316 LHC

Socket head cap screw DIN 912

Stainless Steel AISI 304

INFORMATION

With semi-split Stainless Steel-shaft collars GN 7062.2, e.g., axles are attached to housing, or wheels and washers are installed on shafts.

They can be assembled safely and easily with a high clamping force by reducing the slot height, without damaging the surface of shafts and axles.

The thread d_3 for sizes $d_1 = 30$ to 36 is designed as a through hole; for sizes $d_1 = 42$ and larger, it is designed as blind hole.



TECHNICAL INFORMATION

- ISO-Fundamental tolerances (see page A21)
- Stainless Steel characteristics (see page A26)

ACCESSORY

- Adjustable hand levers GN 311 (see page)
- Damping washer GN 7062.30 (see page)

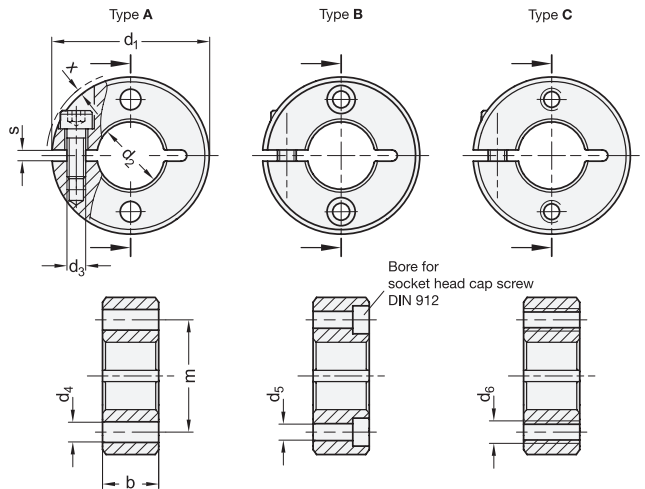

* Complete with type index of the Split Stainless Steel-Shaft collars

- A** with two through holes **B** with two countersunk holes **C** with two tapped holes

GN 7062.2

STAINLESS STEEL

Description	d_1	d_2 H10 Recommended shaft tolerance h11	b ± 0.2	d_3	d_4	d_5	d_6	m	s	$x \approx$ Max. protrusion of cap screw	Adjustable hand lever for d_3	
GN 7062.2-30-B12-NI-*	30	B 12	11	M 4	4.5	3.5	M 4	21	2.1	0.7	311-30-M4-12-SW	38
GN 7062.2-32-B14-NI-*	32	B 14	11	M 4	4.5	3.5	M 4	23	2.1	0.7	311-30-M4-12-SW	41
GN 7062.2-36-B15-NI-*	36	B 15	13	M 5	5.5	4.5	M 5	25.5	2.1	1.4	311-30-M5-13-SW	62
GN 7062.2-36-B16-NI-*	36	B 16	13	M 5	5.5	4.5	M 5	26	2.1	1.4	311-30-M5-13-SW	59
GN 7062.2-42-B18-NI-*	42	B 18	15	M 5	5.5	4.5	M 5	30	3	0.6	311-30-M5-15-SW	97
GN 7062.2-42-B20-NI-*	42	B 20	15	M 5	5.5	4.5	M 5	31	3	0.6	311-30-M5-15-SW	95
GN 7062.2-48-B22-NI-*	48	B 22	15	M 5	6.5	5.5	M 6	35	3	0	311-45-M5-16-SW	123
GN 7062.2-48-B25-NI-*	48	B 25	15	M 5	6.5	5.5	M 6	36.5	3	0	311-45-M5-16-SW	112
GN 7062.2-55-B28-NI-*	55	B 28	15	M 6	6.5	5.5	M 6	41.5	3	0.5	311-45-M6-18-SW	155
GN 7062.2-55-B30-NI-*	55	B 30	15	M 6	6.5	5.5	M 6	42.5	3	0.5	311-45-M6-18-SW	145
GN 7062.2-60-B32-NI-*	60	B 32	15	M 6	6.5	5.5	M 6	46	4	0.4	311-45-M6-19-SW	190
GN 7062.2-60-B35-NI-*	60	B 35	15	M 6	6.5	5.5	M 6	47.5	4	0.4	311-45-M6-19-SW	160
GN 7062.2-65-B40-NI-*	65	B 40	15	M 6	6.5	5.5	M 6	52.5	4	0.5	311-45-M6-20-SW	181

Weight type A