

GN 666.7

Tubular handles



INOX
Stainless Steel



technical informations

Tube

AISI 304 stainless steel, ground matte shiny finish.

Handle shanks

AISI 304 stainless steel, ground matte shiny finish.

Mounting stud

AISI 304 stainless steel, with threaded pin DIN 913-M8.

Grub screw

AISI 304 Stainless Steel DIN 914-M5.

Tube end caps

- Version K: Plastic (Polyamide A), black matte finish.
- Version E: AISI 304 stainless Steel.

Special executions on request (For sufficient quantities)

Different lengths.

Features and applications

For a mounting of Stainless Steel-Tubular handles GN 666.5 (mounting from the back) the stud is first screwed in from the machine side with the threaded pin DIN 913-M8x25 (included) and then the handle is pushed on and secured with the grub screw DIN 914-M5.

Type E of Stainless Steel-Tubular handles GN 666.5 is completely made of A2-Stainless Steel.

Example of application

Tubular handles GN 666.7 allow the mounting of a pair of handles in opposite position. This method could be used on doors (double handle).

Generally a modification of the thread length l_4 is required for this. The included threaded pin DIN 913-M8x25-A2 of the mounting stud needs to be replaced by a longer threaded pin, too. Handles with a modified thread length l_4 are available on request.

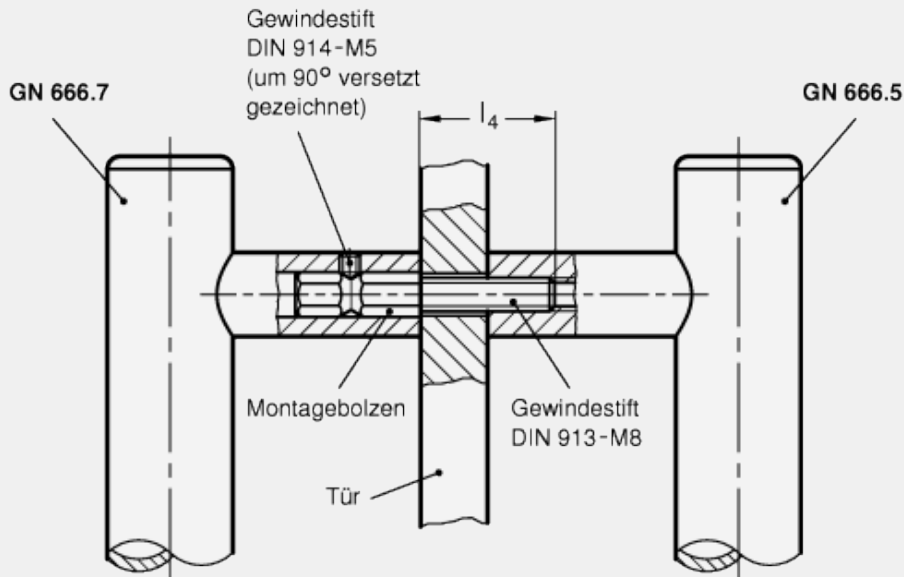

Standard Elements	Main dimensions					Screws			Weight
Description	d_1	$l_1 \pm 0.5$	d_4	h	l_3	d_2	$l_2 \pm 0.3$	l_4	g
GN 666.7-30-M8-200-E	30	200	20	60	265	M8	200	15	480
GN 666.7-30-M8-200-K	30	200	20	60	265	M8	200	15	480
GN 666.7-30-M8-250-E	30	250	20	60	315	M9	250	15	590
GN 666.7-30-M8-250-K	30	250	20	60	315	M8	250	15	590
GN 666.7-30-M8-300-E	30	300	20	60	365	M8	300	15	730
GN 666.7-30-M8-300-K	30	300	20	60	365	M8	300	15	730
GN 666.7-30-M8-400-E	30	400	20	60	465	M8	400	15	800
GN 666.7-30-M8-400-K	30	400	20	60	465	M8	400	15	800
GN 666.7-30-M8-500-E	30	500	20	60	565	M8	500	15	890
GN 666.7-30-M8-500-K	30	500	20	60	565	M8	500	15	890
GN 666.7-30-M8-600-E	30	600	20	60	665	M8	600	15	1000
GN 666.7-30-M8-600-K	30	600	20	60	665	M8	600	15	1000



STANDARD MACHINE ELEMENTS WORLDWIDE