

## Quick release star knobs

### SPECIFICATION

Plastic  
Technopolymer (Polyamide PA)

- shock-resistant
- black, matt finish

Bushing  
Steel zinc plated, blue passivated  
Stainless Steel AISI 303 **NI**

### INFORMATION

Quick release star knobs GN 6336.3 are used in such applications where the knob has to be completely removed after the releasing operation and refitted rapidly for re-clamping.

The knob is tilted over the threaded spindle. When in position, the knob is brought into a straight position for meshing of the two threads on nut and spindle. The knob will then have to be turned only by fraction of a rotation to achieve clamping.

Functional safety exists only if the clamping surface lies at a right angle to the threaded bolt.



### TECHNICAL INFORMATION

- Plastic characteristics (see page A2)
- Stainless Steel characteristics (see page A26)

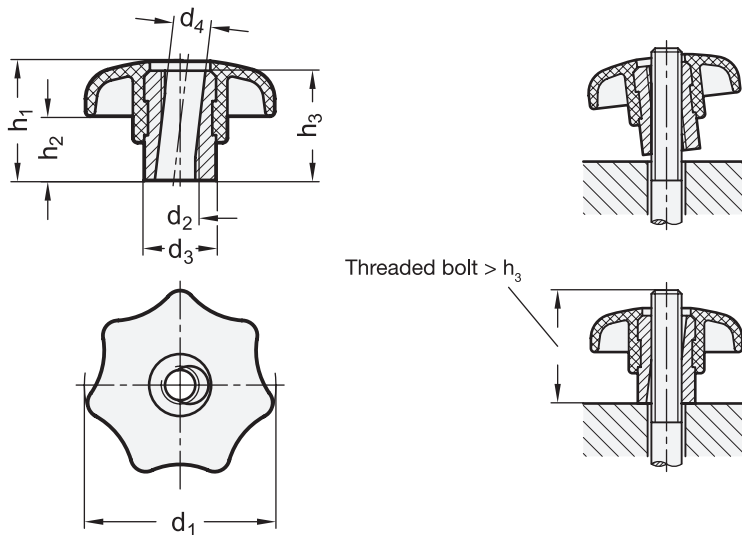

### GN 6336.3

Description	d1	d2	d3	d4	h1	h2 ≈	h3 min.	△
GN 6336.3-40-M8	40	M 8	16	8.4	26	13	24	32
GN 6336.3-50-M10	50	M 10	20	10.5	34	17	30	61
GN 6336.3-63-M12	63	M 12	26	13	42	21	37	121

### GN 6336.3-NI

Description	d1	d2	d3	d4	h1	h2 ≈	h3 min.	△
GN 6336.3-40-M8-NI	40	M 8	16	8.4	26	13	24	32
GN 6336.3-50-M10-NI	50	M 10	20	10.5	34	17	30	59
GN 6336.3-63-M12-NI	63	M 12	26	13	42	21	37	131