

GN 614.1

Holders for smooth ball spring plungers

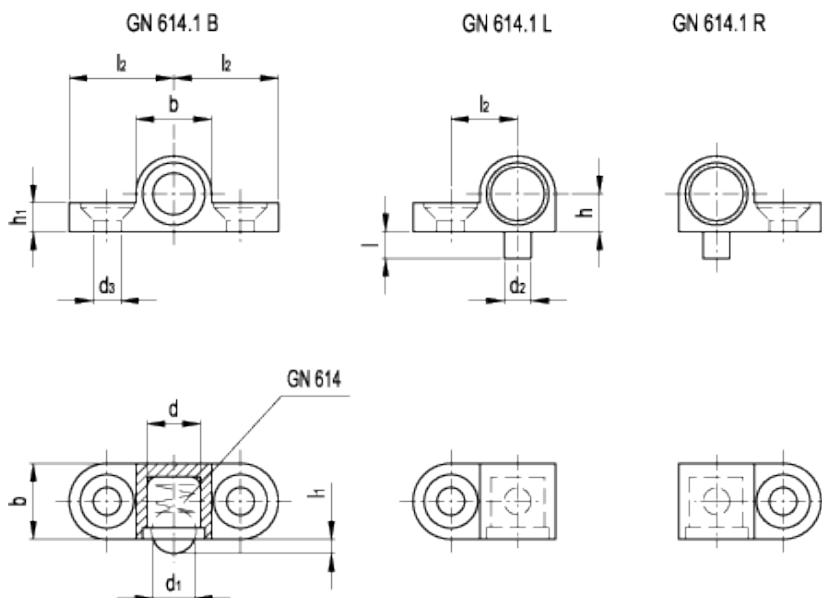

technical informations

Material

Nickel-plated die-cast zinc.

Fixing

- Execution B: two-side fixing wings.
- Execution L: left-side fixing wing with positioning pin.
- Execution R: right-side fixing wing with positioning pin.

Applications

GN 614.1 holders for spring plungers optimise the use of smooth ball spring plungers type [GN 614](#) and [GN 614-NI](#).

Application example

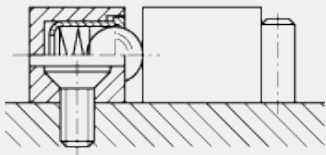

Standard Elements	Main dimensions									Mounting hole		Weight
Description	$d^{-0.05}$	d_1	$d_2^{-0.05}$	b	$h_{\pm 0.05}$	h_1	l	$l_1^{-0.1}$	$l_2^{\pm 0.05}$	d_3	Screw	g
GN 614.1-6-B	6	5	3	8.5	4.25	3.2	3	1.5	7.5	3.2	M3	5
GN 614.1-8-B	8	6.5	4	10.5	5.25	4.2	4	1.8	9.5	4.3	M4	5
GN 614.1-6-L	6	5	3	8.5	4.25	3.2	3	1.5	7.5	3.2	M3	5
GN 614.1-8-L	8	6.5	4	10.5	5.25	4.2	4	1.8	9.5	4.3	M4	5
GN 614.1-6-R	6	5	3	8.5	4.25	3.2	3	1.5	7.5	3.2	M3	5
GN 614.1-8-R	8	6.5	4	10.5	5.25	4.2	4	1.8	9.5	4.3	M4	5



ELESA and GANTER models all rights reserved in accordance with the law. Always mention the source when reproducing our drawings.

STANDARD MACHINE ELEMENTS WORLDWIDE