

GN 613

Indexing plungers

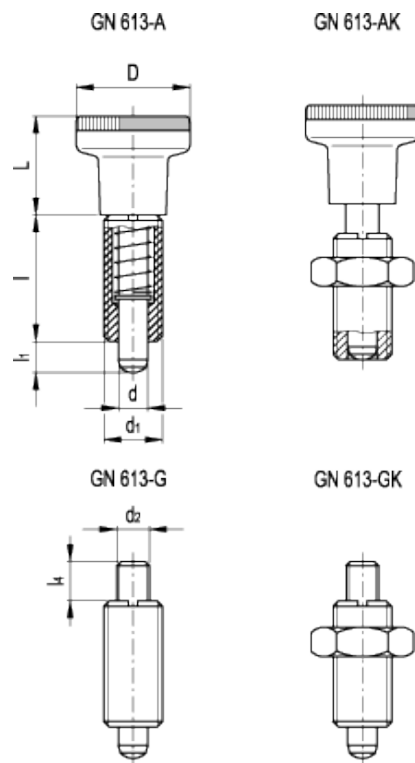

technical informations

Threaded body
Black-oxide steel.

Plunger

Black-oxide steel with hardened end. Suggested matching hole in H7 tolerance.

Locking nut

Black-oxide steel.

"Push/Pull" knurled knob

High resilience polyamide based (PA) technopolymer, black colour, matte finish. Resistant to solvents, oils, greases and other chemical agents.

Standard executions available

- Execution A: with knob, without locking nut.
- Execution AK: with knob and locking nut, ISO 8675.
- Execution G: without knob, without locking nut.
- Execution GK: without knob, with locking nut, ISO 8675.

Executions G and GK, without knob, are provided with threaded drive rod for combination with a knob on customer's request or to join the rod to an operating mechanism of the machine.

Applications

GN 613 indexing plungers are used where positioning operations are required.

Standard Elements	Main dimensions								Spring pressure		Weight	Screw drive
	Description	d ^{-0.02 -0.04}	L	d ₁	d ₂	D	I	I _{1 min.}	I ₄	Preload [N~]	Max. load [N~]	g
GN 613-5-A	5	18	M10x1	-	21	22	5	-	7	17	18	GN 613.1-5
GN 613-6-A	6	22.5	M12x1.5	-	25	26	6	-	9	24	29	GN 613.1-6
GN 613-8-A	8	27	M16x1.5	-	31	34	8	-	11	30	62	GN 613.1-8
GN 613-10-A	10	27	M20x1.5	-	31	43	10	-	19	45	92	GN 613.1-10
GN 613-5-AK	5	18	M10x1	-	21	22	5	-	7	17	25	GN 613.1-5
GN 613-6-AK	6	22.5	M12x1.5	-	25	26	6	-	9	24	38	GN 613.1-6
GN 613-8-AK	8	27	M16x1.5	-	31	34	8	-	11	30	82	GN 613.1-8
GN 613-10-AK	10	27	M20x1.5	-	31	43	10	-	19	45	127	GN 613.1-10
GN 613-5-G	5	18	M10x1	M5	21	22	5	6	7	17	14	GN 613.1-5
GN 613-6-G	6	22.5	M12x1.5	M6	25	26	6	10	9	24	27	GN 613.1-6
GN 613-8-G	8	27	M16x1.5	M8	31	34	8	12	11	30	59	GN 613.1-8
GN 613-10-G	10	27	M20x1.5	M8	31	43	10	12	19	45	86	GN 613.1-10
GN 613-5-GK	5	18	M10x1	M5	21	22	5	6	7	17	21	GN 613.1-5
GN 613-6-GK	6	22.5	M12x1.5	M6	25	26	6	10	9	24	37	GN 613.1-6
GN 613-8-GK	8	27	M16x1.5	M8	31	34	8	12	11	30	79	GN 613.1-8
GN 613-10-GK	10	27	M20x1.5	M8	31	43	10	12	19	45	121	GN 613.1-10



ELESA and GANTER models all rights reserved in accordance with the law. Always mention the source when reproducing our drawings.

STANDARD MACHINE ELEMENTS WORLDWIDE