

GN 612.1

Mounting flanges

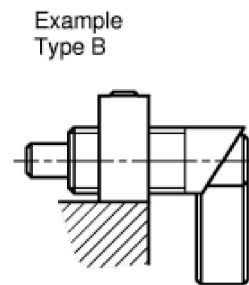
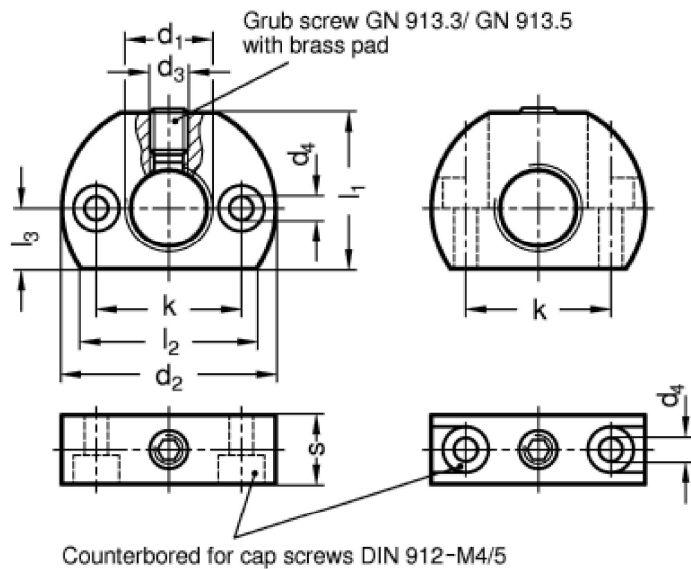

technical informations

Material

Black-oxide steel.

Set screw

Black-oxide steel, GN 913.3-MS type with brass pad.

Types

- Type **A**: fixing holes parallel to plunger.
- Type **B**: fixing holes vertical to plunger

Features and applications

Mounting blocks GN 612.1 broaden to the mounting possibilities and are an added feature for the cam action indexing plungers GN 612 and cam action indexing plungers GN 712 / GN 712.1. They can also be used with indexing plungers GN 613, sizes 6, 8 and 10.

Standard Elements	Main dimensions									Weight
Description	d ₁	d ₂	d ₃	d ₄	k ±0.1	l ₁	l ₂ ≈	l ₃	s	g
GN 612.1-M12x1.5-A	M12x1.5	32	M5	4.5	21	22	26.5	9	12	85
GN 612.1-M12x1.5-B	M12x1.5	32	M5	4.5	21	22	26.5	9	12	91
GN 612.1-M16x1.5-A	M16x1.5	46	M8	5.5	32	33	37	13	15	90
GN 612.1-M16x1.5-B	M16x1.5	46	M8	5.5	32	33	37	13	15	100
GN 612.1-M20x1.5-A	M20x1.5	46	M8	5.5	32	33	37	13	15	95
GN 612.1-M20x1.5-B	M20x1.5	46	M8	5.5	32	33	37	13	15	110



STANDARD MACHINE ELEMENTS WORLDWIDE