

GN 608.1

Indexing plungers with flange and rest position

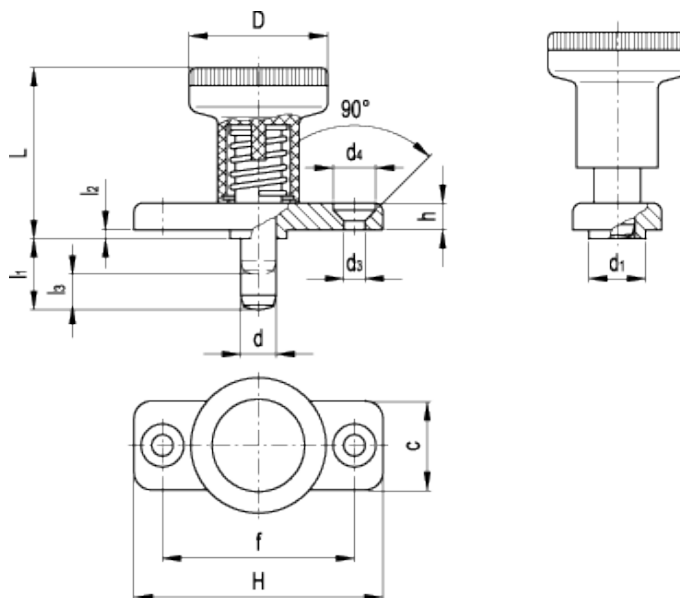

technical informations

Body with flange

Zinc-plated die-cast zinc alloy with two holes for assembly with countersunk head screws.

Plunger

Black-oxide steel with hardened end. Suggested matching hole in H7 tolerance.

"Push/Pull" knurled knob

High resilience polyamide based (PA) technopolymer, black colour, matte finish. Resistant to solvents, oils, greases and other chemical agents.

Applications

GN 608.1 indexing plungers with rest position have compact dimensions and are used on thin metal sheets and where the plunger needs to be locked in the retracted position.

Standard Elements	Main dimensions											Spring pressure		Axial holding force [N]	Weight		
Description	$d_{-0.02-0.04}$	l_1	H	c	$d_1_{-0.02-0.1}$	D	d_3	d_4	f	L	$l_2_{-0.15}$	l_3 stroke	h		Preload [N~]	Max. load [N~]	g
GN 608.1-6-6	6	6	40	18	10	25	4.3	8.3	30	31	2.5	6	4.5	8.5	22	400	36
GN 608.1-6-14	6	14	40	18	10	25	4.3	8.3	30	31	2.5	6	4.5	8.5	22	400	42
GN 608.1-8-8	8	8	46	20	12	31	5.3	10.4	34	36	2.5	8	5.5	15.5	28	500	58
GN 608.1-8-18	8	18	46	20	12	31	5.3	10.4	34	36	2.5	8	5.5	15.5	28	500	66



ELESA and GANTER models all rights reserved in accordance with the law. Always mention the source when reproducing our drawings.

STANDARD MACHINE ELEMENTS WORLDWIDE